

# GWS-090E

Gas-Fired Water Boiler

## Boiler Manual



Contents	Page
1 Prepare boiler location .....	2
2 Prepare boiler .....	8
3 Install water piping .....	9
4 Venting and combustion air .....	12
5 Gas piping .....	12
6 Field wiring .....	13
7 Start-up .....	14
8 Checkout procedure .....	16
9 Sequence of operation .....	17
10 Operating instructions .....	19
11 Service and maintenance .....	20
12 Troubleshooting .....	25
13 Replacement parts .....	33
14 Dimensions .....	38
15 Ratings .....	39

### Hazard definitions

**▲ DANGER** Hazards that **will cause severe** personal injury, death or substantial property damage.

**▲ WARNING** Hazards that **can cause severe** personal injury, death or substantial property damage.

**▲ CAUTION** Hazards that **will or can cause minor** personal injury or property damage.

**NOTICE** Special instructions on installation, operation or maintenance that are important but not related to personal injury or property damage.

**▲ WARNING** **INSTALLER** — Read all instructions before installing. **Read page 2 first.** Follow all instructions in proper order to prevent personal injury or death.

- Consider piping and installation when determining boiler location.
- Any claims for damage or shortage in shipment must be filed immediately against the transportation company by the consignee.

**▲ WARNING** **USER** — Please read the following. Failure to comply could result in severe personal injury, death or substantial property damage.

- **This manual is for use only by your qualified heating installer/service technician.**
- Please see the User's Information Manual for your reference.
- Have the boiler serviced by a qualified service technician, at least annually.

**▲ WARNING** This manual must only be used by a **qualified heating installer/service technician.** Failure to comply could result in severe personal injury, death or substantial property damage.

**NOTICE** When calling or writing about the boiler— Please have:

- boiler model number from the boiler rating label and
- CP number from the boiler jacket. You may list the CP number in the space provided on the "Installation and service certificate" found on page 16.

## Read this first!

**⚠ WARNING** Failure to adhere to the guidelines below can result in severe personal injury, death or substantial property damage.

**⚠ WARNING** The boiler contains ceramic fiber and fiber-glass materials. Use care when handling these materials per instructions on page 21 of this manual. Failure to comply could result in severe personal injury.

### When servicing boiler —

1. To avoid electric shock, disconnect electrical supply before performing maintenance.
2. To avoid severe burns, allow boiler to cool before performing maintenance.

### Boiler operation —

3. Do not block flow of combustion or ventilation air to boiler.
4. Should overheating occur or gas supply fail to shut off, do not turn off or disconnect electrical supply to circulator. Instead, shut off the gas supply at a location external to the appliance.
5. Do not use this boiler if any part has been under water. Immediately call a qualified service technician to inspect the boiler and to replace any part of the control system and any gas control that has been under water.

### Boiler water —

6. DO NOT use petroleum-based cleaning or sealing compounds in boiler system. Water seal deterioration will occur, causing leakage between boiler sections, circulator flanges, diaphragm tanks or other system components. This can result in substantial property damage.
7. DO NOT use “homemade cures” or “boiler patent medicines”. Serious damage to boiler, personnel and/or property may result.
8. Continual fresh makeup water will reduce boiler life. Mineral buildup in sections reduces heat transfer, overheats cast iron, and causes section failure. Addition of oxygen and other gases can cause internal corrosion. Leaks in boiler or piping must be repaired at once to prevent makeup water.
9. Do not add cold water to hot boiler. Thermal shock can cause sections to crack.

### Glycol — potential fire hazard —

All glycol is flammable when exposed to high temperatures. If glycol is allowed to accumulate in or around the boiler or any other potential ignition source, a fire can develop. In order to prevent potential severe personal injury, death or substantial property damage from fire and/or structural damage:

- Never store glycol of any kind near the boiler or any potential ignition source.
- Monitor and inspect the system and boiler regularly for leakage. Repair any leaks immediately to prevent possible accumulation of glycol.
- Never use automotive antifreeze or ethylene glycol in the system. Using these glycols can lead to hazardous leakage of glycol in the boiler system.

## 1 Prepare boiler location

### Codes & checklist

#### Installations must follow these codes:

- Local, state, provincial, and national codes, laws, regulations and ordinances.
- National Fuel Gas Code, ANSI Z223.1—latest edition.
- Standard for Controls and Safety Devices for Automatically Fired Boilers, ANSI/ASME CSD-1, when required.
- National Electrical Code.
- For Canada only: B149.1 or B149.2 Installation Code, CSA C22.1 Canadian Electrical Code Part 1 and any local codes.

**NOTICE** Read and follow the special instructions for the Commonwealth of Massachusetts, located on page 40 of this manual.

### Certification

**NOTICE** The GWS-090E boiler gas manifold and controls met safe lighting and other performance criteria when boiler underwent tests specified in ANSI Z21.13—latest edition.

### Before locating the boiler:

- Check for nearby connection to:
  - System water piping
  - Venting connections
  - Gas supply piping
  - Electrical power
- Check area around boiler. Remove any combustible materials, gasoline and other flammable liquids.

**⚠ WARNING** Failure to keep boiler area clear and free of combustible materials, gasoline and other flammable liquids and vapors can result in severe personal injury, death or substantial property damage.

- Boiler must be installed so that gas control system components are protected from dripping or spraying water or rain during operation or service.
- If new boiler will replace existing boiler, check for and correct system problems, such as:
  1. System leaks causing oxygen corrosion or section cracks from hard water deposits.
  2. Incorrectly-sized expansion tank.
  3. Lack of antifreeze (when required) in boiler water causing system and boiler to freeze and leak.

# 1 Prepare boiler location *continued*

## Clearances

### Service clearances

1. Provide minimum clearances for cleaning and servicing the boiler and for access to controls and components as listed in Table 1 below:
2. Provide at least screwdriver clearance to jacket front panel screws for removal of front panel for inspection and minor service. If unable to provide at least screwdriver clearance, install unions and shutoff valves in system so boiler can be moved for servicing.

**Table 1** Minimum service clearances

Service clearances:	Minimum
Top (for cleaning flueways)	35"
Front (for access to controls and components)	18"
Back	7"
Left side (for cleaning and servicing)	24"
Right side	7"

### Minimum clearance to combustible materials

1. Hot water pipes must be at least ½" from combustible material.
2. Vent pipe must be at least 2 inches from combustible material except where otherwise noted in GWS Venting Manual.

**Figure 1** Minimum clearances in small spaces

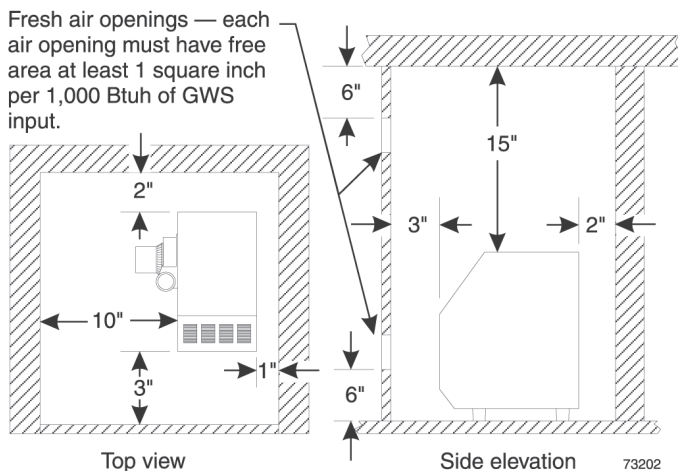

### Small space installations

1. When the boiler is located in a closet or small space, provide clearances no less than those shown in Figure 1. The clearances are required to any surface, whether combustible or non-combustible.

## Residential garage installations

Take the following special precautions when installing the boiler in a residential garage. If the boiler is located in a residential garage, per ANSI Z223.1, paragraph 5.1.9:

- Mount the boiler a minimum of 18 inches above the floor of the garage to assure the burner and ignition devices will be no less than 18 inches above the floor.
- Locate or protect the boiler so it cannot be damaged by a moving vehicle.

## Flooring and foundation

### Flooring

The GWS-090E boiler is approved for installation on combustible flooring, but must never be installed on carpeting.

**WARNING** Do not install boiler on carpeting even if foundation is used. Fire can result, causing severe personal injury, death or substantial property damage.

### Foundation

1. Provide a solid brick or minimum 2-inch thick concrete foundation pad if any of the following is true:
  - floor can become flooded.
  - the boiler mounting area is not level.
2. See Table 2, below, for minimum foundation dimensions.

**Table 2** Minimum foundation size

Boiler model number	Minimum foundation length	Minimum foundation width
GWS-090E	25"	18"

# 1 Prepare boiler location *continued*

## Vent system

**⚠ WARNING** Failure to follow all instructions can result in flue gas spillage and carbon monoxide emissions, causing severe personal injury or death.

**⚠ DANGER** Do not install the GWS-090E into a common vent with any other appliance. This will cause flue gas spillage or appliance malfunction, resulting in possible severe personal injury, death or substantial property damage.

**NOTICE** GWS-090E boilers can only be direct-vent vented. They cannot be chimney-draft vented or direct-exhaust vented. See GWS Venting Manual for detailed installation instructions.

If you are removing an existing boiler from a shared venting system, the GWS-090E boiler cannot share the vent system (it requires its own vent). You must test each appliance remaining on the old common vent system individually to verify the vent system still operates adequately. Follow guidelines below.

### When removing boiler from existing common vent system:

At the time of removal of an existing boiler, the following steps shall be followed with each appliance remaining connected to the common venting system placed in operation, while the other appliances remaining connected to the common venting system are not in operation.

- Seal any unused openings in the common venting system.
- Visually inspect the venting system for proper size and horizontal pitch and determine there is no blockage or restriction, leakage, corrosion or other deficiencies which could cause an unsafe condition.
- Test vent system — Insofar as is practical, close all building doors and windows and all doors between the space in which the appliances remaining connected to the common venting system are located and other spaces of the building. Turn on clothes dryers and any appliance not connected to the common venting system. Turn on any exhaust fans, such as range hoods and bathroom exhausts, so they will operate at maximum speed. Do not operate a summer exhaust fan. Close fireplace dampers.
- Place in operation the appliance being inspected. Follow the lighting/operating instructions. Adjust thermostat so appliance will operate continuously.
- Test for spillage at draft hood relief opening after 5 minutes of main burner operation. Use the flame of a match or candle.
- After it has been determined that each appliance remaining connected to the common venting system properly vents when tested as outlined above, return doors, windows, exhaust fans,

fireplace dampers, and any other gas-burning appliance to their previous conditions of use.

Any improper operation of common venting system should be corrected so the installation conforms with the National Fuel Gas Code, ANSI Z223.1 – latest edition. Correct by resizing to approach the minimum size as determined using the appropriate tables in Part 11 of that code. Canadian installations must comply with B149.1 or B149.2 Installation Code.

### GWS-090E special vent system required

#### Vent system

The GWS-090E boiler requires a special vent system, designed for pressurized venting. Model GWS-090E is rated ANSI Z21.13 Category IV (pressurized vent, likely to condense in the vent).

You may use any of the direct vent systems (combustion air ducted to boiler) covered in GWS Venting Manual included in the boiler envelope assembly. The GWS vent starter is a special item, designed only for GWS and GWS-90E, available from each vendor. Do not attempt to connect the vent to a GWS-090E boiler with any other means.

**⚠ WARNING** DO NOT mix components from different systems. The vent system could fail, causing leakage of flue products into the living space.

#### Vent termination and combustion air supply

The GWS-090E boiler may be vented through the roof or through a side wall. Follow the appropriate instructions in the GWS Venting Manual for the vent system chosen. The maximum vent length depends on boiler size. Refer to the GWS Venting Manual to determine acceptable vent length.

Combustion air for the GWS-090E boiler must be ducted directly to the boiler from outside. For outside air (direct vent installation), two options are available for the flue/air termination. The air supply must **ALWAYS** terminate at the same location as the flue, using either:

- Vertical direct vent installation — Obtain the Through-Roof or Through-Unused Chimney Termination Kit. Refer to the GWS Venting Manual, packed with the kit and to the vent manufacturer's instructions for the vent material chosen.
- Sidewall direct vent installation — Use the Vent/Air Intake Termination Kit shipped with the boiler. Refer to the GWS Venting Manual shipped with the boiler.

# 1 Prepare boiler location *continued*

## Air contamination

Please review the following information on potential combustion air contamination problems.

See Table 3 for products and areas which may cause contaminated combustion air.

**⚠ WARNING** The GWS-90E boiler must be direct vented (using ducted outside air). The vent/air termination must be installed in a location that is free of the contaminants listed in Table 3. Allowing the boiler to operate with contaminated air can cause damage to the boiler and vent system, resulting in possible severe personal injury, death or substantial property damage.

**Table 3** Corrosive contaminants and likely locations

<b>Products to avoid</b>
Spray cans containing chloro/fluorocarbons
Permanent wave solutions
Chlorinated waxes/cleaners
Chlorine-based swimming pool chemicals
Calcium chloride used for thawing
Sodium chloride used for water softening
Refrigerant leaks
Paint or varnish removers
Hydrochloric acid/muriatic acid
Cements and glues
Antistatic fabric softeners used in clothes dryers
Chlorine-type bleaches, detergents, and cleaning solvents found in household laundry rooms
Adhesives used to fasten building products and other similar products
<b>Areas likely to have contaminants</b>
Dry cleaning/laundry areas and establishments
Swimming pools
Metal fabrication plants
Beauty shops
Refrigeration repair shops
Photo processing plants
Auto body shops
Plastic manufacturing plants
Furniture refinishing areas and establishments
New building construction
Remodeling areas
Garages with workshops

# 1 Prepare boiler location *continued*

## Air openings

### Using outside air — direct venting

Combustion air can be ducted directly from outside to the GWS-090E boiler air intake fitting. This method is defined as **direct vent** (also referred to as sealed combustion). Refer to the appropriate instructions in the GWS Venting Manual and the instructions in this manual. Two options are available: sidewall or vertical direct vent. Each requires a special vent component kit.

### Sizing air openings

Air openings provide for ventilation to prevent overheating of the boiler controls and boiler space. Air is also needed for other appliances located in the same space.

Use Figure 2, page 7, selecting the appropriate installation conditions. Note that the sizing given in Figure 2 applies only to GWS-090E installations with clearances no smaller than shown in Table 1, page 3 of this manual. For smaller clearances, regardless of how the air openings are arranged, two openings providing free area of 1 square inch per 1,000 Btuh input of all appliances in the space are required.

**NOTICE**

Air openings must be sized to handle all appliances and air movers (exhaust fans, etc.) using the air supply.

The sizing given in Figure 2 is based on the National Fuel Gas Code, ANSI Z223.1, allowing adequate air opening for gravity-vented gas appliances. The air openings recommended in Figure 2 will allow adequate ventilation and combustion air provided the boiler room is not subjected to negative pressure due to exhaust fans or other mechanical ventilation devices. Refer to the National Fuel Gas Code for dealing with other conditions.

### Louver allowance

The free area of openings means the area after reduction for any installed louvers or grilles. Be sure to consider this reduction when sizing the air openings.

## Special considerations

### Tight construction

ANSI Z223.1 defines unusually tight construction where:

- a. Walls and ceilings exposed to the outside atmosphere have a continuous water vapor retarder with a rating of 1 perm or less with openings gasketed, and . . .
- b. Weather-stripping has been added on openable windows and doors, and . . .
- c. Caulking or sealants are applied to areas such as joints around windows and door frames, between sole plates and floors, between wall-ceiling joints, between wall panels, at penetrations for plumbing, electrical, and gas lines, and in other openings.

For buildings with such construction, provide air openings into the building from outside, sized per the appropriate case in Figure 2.

### Exhaust fans and air movers

The appliance space must never be under a negative pressure, unless the appliances are installed as direct vent. Always provide air openings sized not only to the dimensions required for the firing rate of all appliances, but also to handle the air movement rate of the exhaust fans or air movers using air from the building or space.

### Motorized air dampers



If the air openings are fitted with motorized dampers, electrically interlock the damper to:

- Prevent the boiler from firing if the damper is not fully open.
- Shut the boiler down should the damper close during boiler operation.

To accomplish this interlock, wire an isolated contact (proving the damper open) in series with the thermostat input to the boiler. The boiler will not start if this contact is open, and will shut down should it open during operation.

# 1 Prepare boiler location *continued*

**Figure 2** Provide minimum air openings for GWS-090E boiler installations based on following:

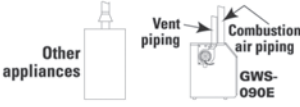
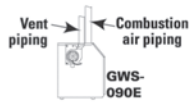
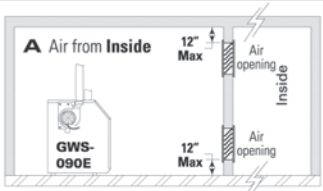
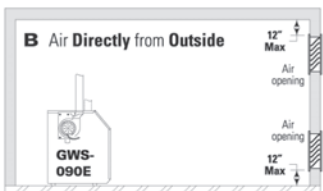
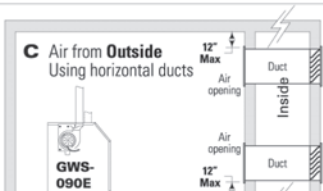
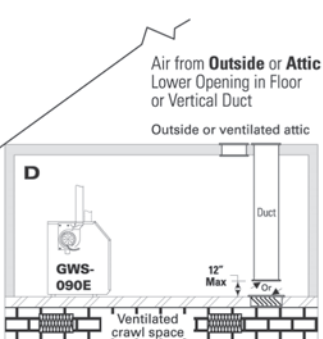
<b>Room Air Openings</b> (See Exception) Required area of the air openings given in this table are <b>free area</b> — after the correction for louver obstruction.	<b>Direct vent installation</b>  (combustion air must be piped to GWS-090E)	
<p> Apply sizing information in this table (Figure 2) only to installations with clearances no smaller than those shown in Table 1, page 3 of this manual. For installations with clearances <b>less</b> than shown in Table 1, page 3 of this manual, provide 2 openings, each with 1 square inch of free area per 1,000 Btuh of total input of all appliances.</p>	 <p>Room <b>shared</b> with other appliances</p>	 <p>GWS <b>alone</b> in room</p>
 <p><b>A</b> Air from <b>Inside</b></p>	<p><b>2</b> Openings, each —  <b>1</b> square inch free area per <b>1,000</b> Btuh input of other appliances (do not include <b>GWS</b> input)</p>	<p><b>NO</b> Openings are needed, <b>provided:</b>                      Clearance around boiler is <b>NO LESS</b> than shown in <b>Table 1</b>, page 3 of this manual.</p>
 <p><b>B</b> Air <b>Directly</b> from <b>Outside</b></p>	<p><b>2</b> Openings, each —  <b>1</b> square inch free area per <b>4,000</b> Btuh input of other appliances (do not include <b>GWS</b> input)</p>	<p><b>NO</b> Openings are needed, <b>provided:</b>                      Clearance around boiler is <b>NO LESS</b> than shown in <b>Table 1</b>, page 3 of this manual.</p>
 <p><b>C</b> Air from <b>Outside</b> Using horizontal ducts</p>	<p><b>2</b> Openings, each —  <b>1</b> square inch free area per <b>2,000</b> Btuh input of other appliances (do not include <b>GWS</b> input)</p>	<p><b>NO</b> Openings are needed, <b>provided:</b>                      Clearance around boiler is <b>NO LESS</b> than shown in <b>Table 1</b>, page 3 of this manual.</p>
 <p>Air from <b>Outside</b> or <b>Attic</b> — Lower Opening in Floor or Vertical Duct</p> <p>Outside or ventilated attic</p> <p>Ventilated crawl space</p>	<p><b>2</b> Openings, each —  <b>1</b> square inch free area per <b>4,000</b> Btuh input of other appliances (do not include <b>GWS</b> input)</p>	<p><b>NO</b> Openings are needed, <b>provided:</b>                      Clearance around boiler is <b>NO LESS</b> than shown in <b>Table 1</b>, page 3 of this manual.</p>
<p><b>Exception to combustion air opening rules:</b></p>	<p><b>NO</b> combustion air openings are needed when the boiler (and other appliances) are installed in a space with a volume <b>NO LESS</b> than 50 cubic feet per 1,000 Btuh of all installed appliances. Sum the total input of all appliances in MBH (1,000's of Btuh) and multiply this number times 50. <b>Building must not be of Tight construction</b> (see page 6).  <b>Example:</b> For total input of 100 MBH (100,000 Btuh), minimum volume is <math>50 \times 100 = 5,000</math> cubic feet. At a ceiling height of 8 feet, space must have at least <math>5,000 \div 8 = 625</math> square feet (25 feet x 25 feet, for instance).</p>	

73201E

## 2 Prepare boiler

### Placement and setup

#### Place boiler/crate near position

1. Leave boiler in crate and on pallet until installation site is ready.
2. Move entire crate and pallet next to selected location.
3. Remove crate. Leave boiler on pallet.
4. Remove boiler from pallet as follows:
  - a. Tilt left side of boiler up and place a board under left legs.
  - b. Tilt boiler the other way and place a board under right legs.
  - c. Slide boiler backwards off pallet and into position.

**NOTICE** Do not drop boiler or bump jacket on floor or pallet. Damage to boiler can result.

5. Check level.
  - a. Shim legs, if necessary.
  - b. Do not alter legs.

#### Inspect orifices and burners; connect air adapter

1. Remove front jacket door. Remove air adapter fitting from air inlet hose (see Figure 17, page 35, items 9 and 10) and screw into opening on jacket top. Reconnect air hose to bottom of air adapter fitting. Remove inlet air box top panel. (See Figure 16, item 13, page 34).
2. Check for correctly-sized manifold orifices. See Table 4 for sizing. (The orifice size is stamped on the orifice spud barrel.)

**⚠ DANGER** Correctly-sized manifold orifices must be used. Failure to do so will result in severe personal injury, death or substantial property damage.

3. Reinstall inlet air box top panel and jacket door.

**⚠ WARNING** Do not operate boiler without inlet air box top panel secured in place. Failure to comply could result in severe personal injury, death or substantial property damage.

**Table 4** Manifold orifice sizing

Location	Natural gas		Propane gas	
	Sea level – 2,000 ft	over 2,000 ft	Sea level – 2,000 ft	over 2,000 ft
U. S.	2.55 mm	(Note 1)	1.60 mm	(Note 1)
Canada	2.55 mm	2,000 – 4,500 # 41	Sea level – 2,000 ft	2,000 – 4,500 1.45 mm

Note 1: For U. S. elevations above 2,000 feet, contact your local supplier for details.

### Pressure test

#### Perform hydrostatic pressure test

Pressure test boiler before attaching water or gas piping or electrical supply (except as noted below).

#### Prepare boiler for test

1. Remove the shipping nipple (from GWS-090E supply tapping) and remove the boiler relief valve. Temporarily plug the relief valve tapping with a 3/4" NPT pipe plug.
2. Remove 1 1/4" nipple, reducing tee and drain valve from accessory bag. Install in boiler return connection as shown on in Figure 18, item 3, page 36. Install circulator on either the return or supply.
3. Remove 1 1/4" nipple, 1 1/4" tee, bushing and pressure/temperature gauge from accessory bag. Pipe to boiler supply connection as shown in Figure 18, item 2, page 36. (Use pipe dope sparingly.)
4. Connect a hose to boiler drain valve, the other end connected to a fresh water supply. Make sure hose can also be used to drain boiler after test.
5. Connect a nipple and shutoff valve to system supply connection on the 1 1/4" tee. This valve will be used to bleed air during the fill. (Valve and nipple are not included with boiler.)
6. Connect a nipple and shutoff valve to system return connection (at circulator flange if circulator installed on return). This valve will be used to bleed air during the fill. (Valve and nipple are not included with boiler.)

#### Fill and pressure test

1. Open the shutoff valves you installed on supply and return connections.

2. Slowly open boiler drain valve and fresh water supply to fill boiler with water.
3. When water flows from shutoff valves, close boiler drain valve.
4. Close shutoff valves.
5. Slowly reopen boiler drain valve until test pressure of not more than 45 psi is reached on the pressure/temperature gauge.
6. Test at no more than 45 psi for no more than 10 minutes.

**⚠ WARNING** Do not leave boiler unattended. A cold water fill could expand and cause excessive pressure, resulting in severe personal injury, death or substantial property damage.

7. Make sure constant gauge pressure has been maintained throughout test. Check for leaks. Repair if found.

**⚠ WARNING** Leaks must be repaired at once. Failure to do so can damage boiler, resulting in substantial property damage.

**⚠ DANGER** Do not use petroleum-based cleaning or sealing compounds in boiler system. Severe damage to boiler will occur, resulting in substantial property damage.

#### Drain and remove fittings

1. Disconnect fill water hose from water source.
2. Drain boiler at drain valve or out hose, whichever provides best access to drain. Remove hose after draining if used to drain boiler.
3. Remove nipples and valves unless they will remain for use in the system piping.
4. Remove plug from relief valve tapping. See Section 3, page 9, to replace relief valve.



### 3 Install water piping

#### General

If installation is to comply with ASME or Canadian requirements, an additional high temperature limit is needed. Install control in supply piping between boiler and isolation valve. Set second control to minimum 20 °F above setpoint of first control. Maximum allowable setpoint is 240 °F. See page 18 for wiring.

A low water cutoff device is required when boiler is installed above radiation level or by certain state or local codes or insurance companies. Use low water cutoff designed for water installations. Electrode probe-type is recommended. Purchase and install in tee in supply piping above boiler.

Use backflow check valve in cold water supply if required by local codes.

#### Near-boiler piping

See Figure 3 (diaphragm-type or bladder-type expansion tank) or Figure 4 (closed-type expansion tank) on page 10, and Table 5, for near-boiler and single-zone systems designed for return water at least 130 °F.

See page 9 for multiple zone systems.

See page 10 for boilers used with refrigeration systems.

#### Relief valve

Install relief valve vertically in ¾" tapping on side of boiler. See the tag attached to the relief valve for manufacturer's instructions.

- ⚠ WARNING** To avoid water damage or scalding due to valve operation, discharge line must be connected to relief valve outlet and run to a safe place of disposal. Terminate the discharge line to eliminate possibility of severe burns should the valve discharge.
- Discharge line must be as short as possible and be the same size as the valve discharge connection throughout its entire length.
  - Discharge line must pitch downward from the valve and terminate at least 6" above the floor drain where any discharge will be clearly visible.
  - The discharge line shall terminate plain, not threaded, with a material serviceable for temperatures of 375 °F or greater.
  - Do not pipe the discharge to any place where freezing could occur.
  - No shutoff valve shall be installed between the relief valve and boiler, or in the discharge line. Do not plug or place any obstruction in the discharge line.
  - Failure to comply with the above guidelines could result in failure of the relief valve to operate, resulting in possibility of severe personal injury, death or substantial property damage.
  - Test the operation of the valve after filling and pressurizing system by lifting the lever. Make sure the valve discharges freely. If the valve fails to operate correctly, replace it with a new relief valve.

#### Near-boiler piping *continued*

**Table 5** Water pipe size (based on 20 °F rise)

Boiler model number	To system	From system
GWS-090E	1"	1"

#### Circulator

The circulator is shipped loose (wiring pre-attached to boiler) to allow you to locate it either in the return or supply piping, as desired. See Figures 3 and 4, page 10, for a typical installation. Pipe the expansion tank to the suction side of the circulator whenever possible. Install an air separator in the supply piping. Connect the expansion tank to the air separator only if the separator is on the suction side of the circulator. Always install the system fill connection at the same point as the expansion tank connection to the system.

#### Expansion tank

##### Diaphragm- or bladder-type expansion tank — Figure 3, page 10

1. Ensure expansion tank size will handle boiler and system water volume and temperature. Tank must be located in boiler return piping as close to boiler as possible, before inlet side of circulator. See tank manufacturer's instructions for details.
2. Install an automatic air vent as shown.

##### Closed-type expansion tank — Figure 4, page 10

1. Ensure expansion tank size will handle boiler and system water volume and temperature. See tank manufacturer's instructions for details.
2. Connect tank to ½" NPT tapping located behind supply outlet, using ½" NPT piping. Pitch any horizontal piping up towards tank 1 inch per 5 feet of piping.

**⚠ CAUTION** Undersized expansion tanks cause system water to be lost from relief valve and makeup water to be added through fill valve. Eventual section failure can result.

#### Water piping — multiple zone systems

Install system piping using either circulator zoning or zone valve zoning. Install expansion tank on suction side of system pump. Always connect fill line only at the expansion tank — never at another point in the system.

### 3 Install water piping *continued*

**Figure 3** Diaphragm- or bladder-type expansion tank: Piping to single-zone system using diaphragm-type or bladder-type expansion tank. See Table 5, page 9, for piping sizes.

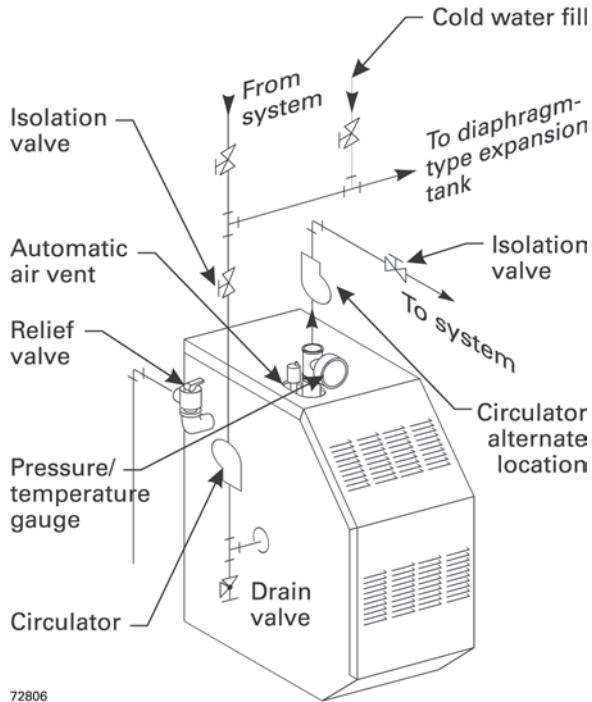

72806

**Figure 4** Closed-type expansion tank: Piping to single-zone system using closed-type expansion tank. See Table 5, page 9, for piping sizes.

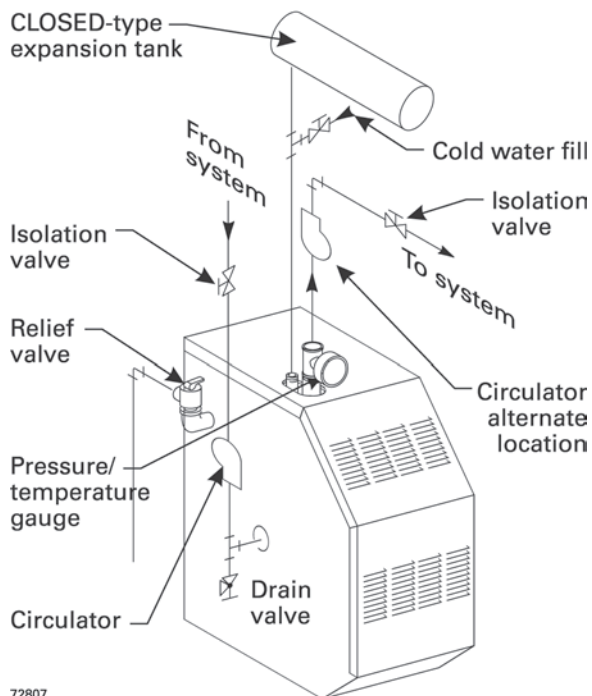

72807

**WARNING** Use Figure 3 or Figure 4 only for systems designed for return water at least 130 °F. For systems with low return water temperature possible, such as converted gravity systems and radiant heating systems, install bypass piping (see page 11) to protect boiler against condensation. Failure to prevent low return water temperature to the boiler could cause corrosion of the boiler sections or burners, resulting in severe personal injury, death or substantial property damage.

**WARNING** If system includes radiant heating circuits, provide piping and controls to regulate the temperature supplying the radiant circuits. Failure to comply could result in substantial property damage.

**WARNING** Install boiler so that chilled medium is piped in parallel with heating boiler. Use appropriate valves to prevent chilled medium from entering boiler. Consult I=B=R Installation and Piping Guides.

If boiler is connected to heating coils located in air handling units where they can be exposed to refrigerated air, use flow control valves or other automatic means to prevent gravity circulation during cooling cycle. Circulation of cold water through the boiler could result in damage to the heat exchanger, causing possible severe personal injury, death or substantial property damage.

#### Water piping — refrigeration systems

##### Prevent chilled water from entering boiler

Install boiler so that chilled medium is piped in parallel with the heating boiler. Use appropriate valves to prevent chilled medium from entering boiler. See Figure 5 for typical installation of balancing valve and check valve.

**Figure 5** Piping refrigeration systems

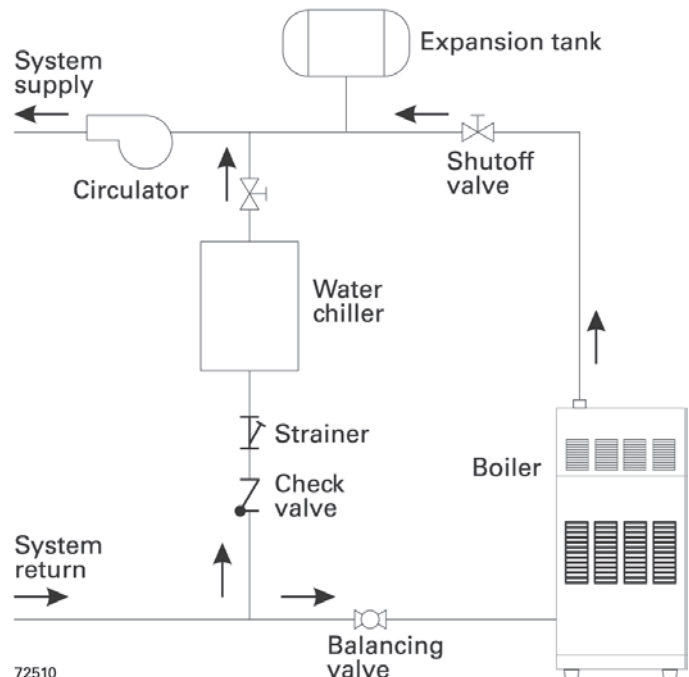

72510

### 3 Install water piping *continued*

#### Near-boiler piping *continued*

**Figure 6** System bypass piping in boiler loop with separate system circulator, using primary/secondary piping

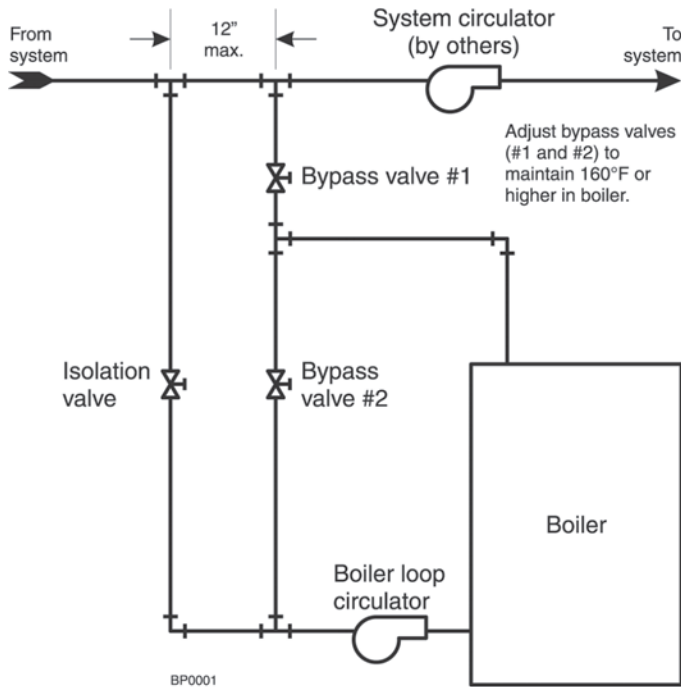

**Figure 7** Boiler bypass piping — use only for high water content systems — DO NOT use for radiant panel systems

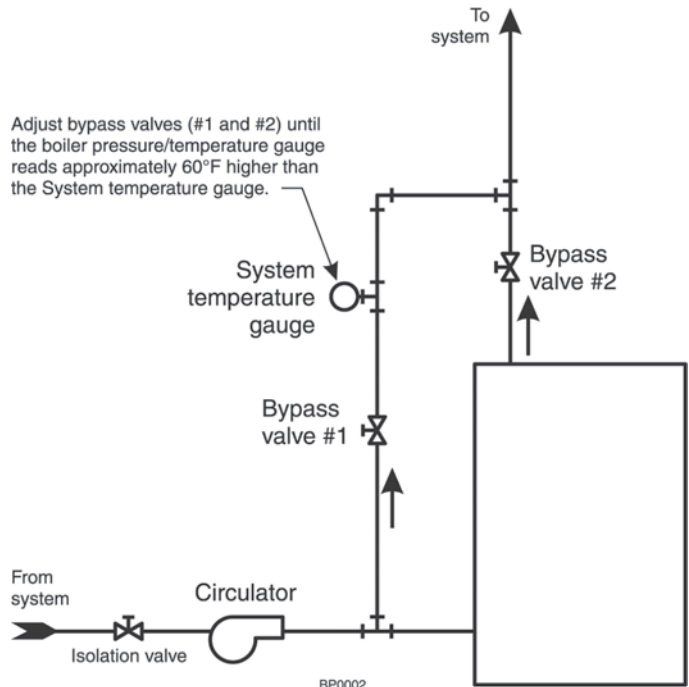

#### System bypass method

1. Apply bypass piping of Figure 6 to high water content systems, radiant panel systems or any system that is likely to operate with low return water temperature for extended periods.
2. The bypass arrangement shown protects the boiler from damage caused by condensate corrosion due to low return water temperature and protects low temperature systems from too high a supply temperature.
3. Adjust the bypass valves as indicated below.

#### Adjust Bypass valves 1 and 2 as follows:

1. Start with valve 2 fully closed, valve 1 fully open.
2. Slowly open valve 2 while closing valve 1. Adjust the valves until the boiler pressure/temperature gauge reads 160 °F or higher. As you open the valves, pause long enough to allow temperatures to level off. It takes a while for the boiler water temperature to rise as the flow changes.
3. Bypass valve 2 allows hot boiler outlet water to blend with colder return water, raising the supply temperature to the boiler. Bypass valve 1 balances the pressure drop through valve 2.
4. The purpose of this piping is to raise the return water temperature to the boiler enough to prevent condensation of flue gases.

#### Boiler bypass method

1. Apply bypass piping of Figure 7 to high water content systems, such as converted gravity systems.
2. The bypass arrangement shown protects the boiler from damage caused by condensate corrosion due to low return water temperature. This method does not provide protection from high temperature water being supplied to the system.
3. DO NOT apply this piping to radiant panel systems.
4. Adjust the bypass valves as indicated below.

#### Adjust Bypass valves 1 and 2 as follows:

1. Start with valve 1 fully closed, valve 2 fully open.
2. Slowly open valve 1 while closing valve 2. Adjust the valves until the boiler pressure/temperature gauge reads approximately 60 °F higher than the system temperature gauge. As you open the valves, pause long enough to allow temperatures to level off. It takes a while for the boiler water temperature to rise as the flow changes.
3. Bypass valve 1 controls system flow rate. Bypass valve 2 controls flow through the boiler.
4. The purpose of this piping is to cause a high enough temperature rise in the boiler that the average temperature will be warm enough to prevent condensation of flue gases.

**WARNING** Install all components specified above and adjust valves as described to prevent low temperature in the boiler. Failure to prevent low water temperature in the boiler could cause corrosion of the boiler sections or burners, resulting in severe personal injury, death or substantial property damage.

## 4 Venting and combustion air

Install vent piping and air piping (if used) per appropriate instructions in the GWS Venting Manual, included in boiler envelope assembly.

Refer to GWS Venting Manual and to Boiler Manual Section 1, page 4, regarding requirements for:

- vent system
- combustion air openings
- combustion air quality

**⚠ DANGER**

The GWS-090E boiler must be direct vented only (combustion air ducted to boiler) and supplied with combustion and ventilation air as described in GWS Venting Manual, packed in envelope assembly with boiler, and Section 1 of this manual, page 4. Failure to do so will cause severe personal injury or death.

**NOTICE**

Read and follow the special instructions for the Commonwealth of Massachusetts, located on page 40 of this manual.

## 5 Gas piping

1. Remove jacket front panel and see Figure 8 to pipe gas to boiler.
  - a. Install drip leg at inlet of gas connection to boiler. Where local utility requires drip leg to be extended to the floor, use appropriate length of nipple between cap and tee.
  - b. Install ground joint union for servicing, when required.
  - c. Install manual shutoff valve in gas supply piping outside boiler jacket when required by local codes or utility requirements.
  - d. In Canada — When using manual main shutoff valve, it must be identified by the installer.
2. Support piping with hangers, not by boiler or its accessories.
3. Purge all air from gas supply piping.
4. Before placing boiler in operation, check boiler and its gas connection for leaks.
  - a. Close manual main shutoff valve during any pressure testing at less than 13" w.c.
  - b. Disconnect boiler and gas valve from gas supply piping during any pressure testing greater than 13" w.c.

**⚠ WARNING** Do not check for gas leaks with an open flame — Use bubble test. Failure to use bubble test or check for gas leaks can cause severe personal injury, death or substantial property damage.

5. Use pipe dope compatible with propane gases. Apply sparingly only to male threads of pipe joints so that pipe dope does not block gas flow.

**⚠ WARNING** Failure to apply pipe dope as described in this manual can result in severe personal injury, death or substantial property damage.

### Natural Gas:

1. See Table 6 for pipe length and diameter. Base on rated boiler input (divide by 1,000 to obtain cubic feet per hour). Table 6 is only for gas with specific gravity 0.60, with a pressure drop through the gas piping of 0.30" w.c. For additional gas pipe sizing information, see ANSI Z223.1 (B149.1 or B149.2 for Canadian installations).
2. Inlet pressure required at gas valve inlet:
  - Maximum: 13" w.c.
  - Minimum: 5" w.c.
  - Manifold gas pressure: 3.5" w.c. at high fire (0.90" w.c. at low fire while in low fire at start-up)
3. Install 100% lockup gas pressure regulator in supply line if inlet pressure exceeds 13" w.c. Adjust for 13" w.c. maximum.

### Propane Gas:

1. Contact gas supplier to size pipes, tanks and 100% lockup gas pressure regulator.
2. Adjust propane supply regulator provided by gas supplier for 13" w.c. maximum pressure.
3. Inlet pressure required at gas valve inlet:
  - Maximum: 13" w.c.
  - Minimum: 11" w.c.
  - Manifold gas pressure: 10" w.c. at high fire (3.5" w.c. at low fire while in low fire at start-up)

**Table 6** Pipe capacity for 0.60 specific gravity natural gas

Gas pipe length (feet)	Capacity of pipe for pipe size of: (Capacity in standard cubic feet gas per hour)				
	½"	¾"	1"	1¼"	1½"
10	132	278	520	1050	1600
20	92	190	350	730	1100
30	73	152	285	590	860
40	63	130	245	500	760
50	56	115	215	440	670
75	45	93	175	360	545
100	38	79	150	305	460
150	31	64	120	250	380

**Figure 8**

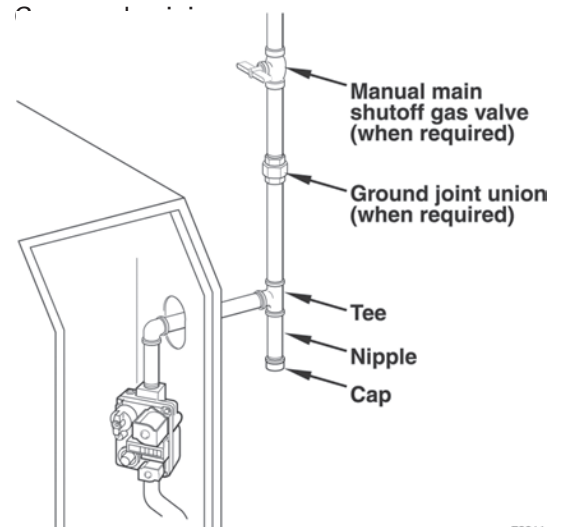

72811

## 6 Field wiring

**WARNING** For your safety, turn off electrical power supply at service entrance panel before making any electrical connections to avoid possible electric shock hazard. Failure to do so can cause severe personal injury or death.

**NOTICE** Wiring must be N.E.C. Class 1. If original wiring as supplied with boiler must be replaced, use only type 105 °C wire or equivalent. Boiler must be electrically grounded as required by National Electrical Code ANSI/NFPA 70-latest edition.

### Electrical installation must comply with:

1. National Electrical Code and any other national, state, provincial or local codes or regulations.
2. In Canada, CSA C22.1 Canadian Electrical Code Part 1, and any local codes.

### Wiring connections

Boiler is shipped with controls completely wired, except spill switch and vent damper. See wiring diagram on page 18. Circulator is shipped loose, but wiring harness is pre-attached to the boiler. Connect wires in circulator junction box.

### Thermostat

1. Connect thermostat as shown on wiring diagram on boiler.
2. Install on inside wall away from influences of drafts, hot or cold water pipes, lighting fixtures, television, sunrays or fire-places.
3. If thermostat has a heat anticipator, set heat anticipator in thermostat to match power requirements of equipment connected to it. If connected directly to boiler, set per wiring diagram, Figure 13, on page 18. For other devices, see manufacturer's specifications. Also see instructions with thermostat.

### Junction box (furnished)

1. Connect 120 VAC power wiring. See Figure 9.
2. Fused disconnect or service switch (15 amp. recommended) may be mounted on this box. For those installations with local codes which prohibit installation of fused disconnect or service switch on boiler, install a 2 x 4 cover plate on the boiler junction box and mount the service switch remotely as required by the code.

### Wiring multiple zones

See zone valve manufacturer's literature for wiring and application. A separate transformer is required to power zone valves. Zoning with circulators requires a relay for each circulator.

Figure 9 Field wiring connections — service switch and thermostat (or end switch) provided by installer

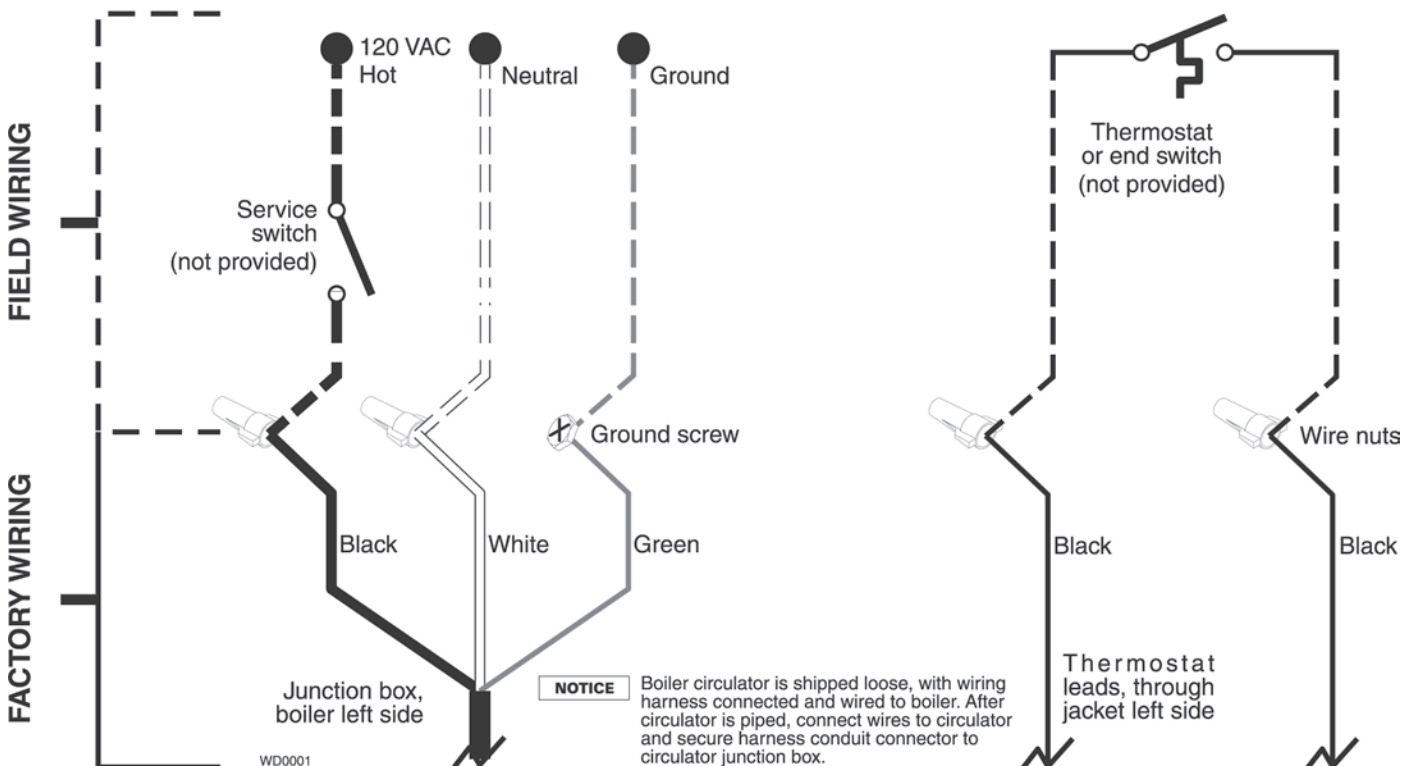

**NOTICE** The GWS-090E control module is polarity-sensitive. The hot and neutral wires must be connected to the correct leads. A flashing **POWER** light usually indicates reversed polarity of 120 VAC lead wires.

## 7 Start-up

### Check for gas leaks

**⚠ WARNING** Before starting the boiler, and during initial operation, smell near the floor and around the boiler for gas odorant or any unusual odor. Do not proceed with start-up if there is any indication of a gas leak. Repair any leak at once.

**⚠ WARNING** Propane boilers only — Your propane supplier mixes an odorant with the propane to make its presence detectable. In some instances, the odorant can fade and the gas may no longer have an odor.

- Propane gas can accumulate at floor level. Smell near the floor for the gas odorant or any unusual odor. If you suspect a leak, do not attempt to light the pilot.
- Use caution when attempting to light the propane pilot. This should be done by a qualified service technician, particularly if pilot outages are common.
- Periodically check the odorant level of your gas.
- Inspect boiler and system at least yearly to make sure all gas piping is leak-tight.
- Consult your propane supplier regarding installation of a gas leak detector. There are some products on the market intended for this purpose. Your supplier may be able to suggest an appropriate device.

### Determine if water treatment is needed

**⚠ DANGER** Do not use petroleum-based cleaning or sealing compounds in boiler system. Severe damage to boiler will occur, resulting in substantial property damage.

**⚠ WARNING** Eliminate all system leaks. Continual fresh makeup water will reduce boiler life. Minerals can build up in sections, reducing heat transfer, overheating cast iron, and causing section failure.

### Verify water chemistry

Consult local water treatment companies for unusually hard water areas (above 7 grains hardness) or low pH water conditions (below 7.0). Boiler water pH of 7.0 to 8.5 is recommended.

### Freeze protection (when used)

Use antifreeze made especially for hydronic systems. Inhibited propylene glycol is recommended.

**⚠ WARNING** Do not use ethylene glycol, automotive or undiluted antifreeze. Severe personal injury or death can result.

1. Determine antifreeze quantity according to system water content. Boiler water content is listed on page 39. Remember to include expansion tank water content.
2. Follow antifreeze manufacturer's instructions.
3. A 50% solution of propylene glycol/water provides maximum protection to about -30 °F.
4. Local codes may require back flow preventer or actual disconnect from city water supply.
5. When using antifreeze in a system with automatic fill, install a water meter to monitor water makeup. Glycol will leak before the water begins to leak, causing glycol level to drop. Added water will dilute the antifreeze, reducing the freeze protection level.

### Fill the system with water

1. Close manual and automatic air vents and boiler drain cock.
2. Fill to correct system pressure. Correct pressure will vary with each application. Typical cold water fill pressure for a residential system is 12 psi.
3. Purge air from system:
  - a. Connect a hose to purge valve or valves, if installed. Route hose to an area where water can drain and be seen.
  - b. Close the boiler or system isolation valve between the purge valve and fill connection to the system.
  - c. Close zone isolation valves.
  - d. Open quick-fill valve on cold water makeup line.
  - e. Open purge valve.
  - f. One zone at a time, open the isolation valves. Allow water to run through the zone, pushing out the air. Run until no noticeable air flow is present. Close the zone isolation valves and proceed with the next zone. Follow this procedure until all zones are purged.
  - g. Close the quick-fill water valve and purge valve and remove the hose. Open all isolation valves. Watch that system pressure rises to correct cold-fill pressure.
  - h. After the system has operated for a while, eliminate any residual air by using the manual air vents located throughout the system.
  - i. If purge valves are not installed in system, open manual air vents in system one at a time, beginning with lowest floor. Close vent when water squirts out. Repeat with remaining vents.
4. Open automatic air vent (diaphragm-type or bladder-type expansion tank systems only) one turn.
5. Open other vents:
  - a. Starting on the lowest floor, open air vents one at a time until water squirts out.
  - b. Repeat with remaining vents.
6. Refill to correct pressure.

### Inspect system water piping

After filling the boiler and system with water, inspect all piping throughout the system for leaks. If found, repair immediately. Repeat this inspection after the boiler has been started and the system has heated up.

**⚠ WARNING** Leaks must be repaired at once. Failure to do so can damage the boiler, resulting in substantial property damage.

**⚠ DANGER** Do not use petroleum-based cleaning or sealing compounds in boiler system. Severe damage to boiler will occur, resulting in substantial property damage.

### Inspect base insulation

**⚠ WARNING** The boiler contains ceramic fiber and fiberglass materials. Use care when handling these materials per instructions on page 21 of this manual. Failure to comply could result in severe personal injury.

Check to make sure insulation is secure against all four sides of the base. If insulation is damaged or displaced, do not operate boiler. Replace or reposition insulation.

**⚠ WARNING** Failure to replace damaged insulation or reposition insulation can result in a fire hazard, causing severe personal injury, death or substantial property damage.

## 7 Start-up *continued*

### Operate boiler

**▲WARNING** DO NOT proceed with boiler operation unless boiler and system have been filled with water and all instructions and procedures of previous manual sections have been completed. Failure to do so could result in severe personal injury, death or substantial property damage. Before starting the boiler . . .

- Read manual Sections 8 and 9 and “Operating instructions”, page 19.
- Verify the boiler and system are full of water.
- Verify the Start-up preparation procedures of this section have been completed.

### Start the boiler

Follow “Operating instructions”, page 19. If boiler fails to start, see “If boiler doesn’t start . . . Check for:” on this page.

### Check system and boiler

**▲WARNING** Eliminate all system leaks. Continual fresh makeup water will reduce boiler life. Minerals can build up in sections, reducing heat transfer, overheating cast iron, and causing section failure.

**▲WARNING** If you discover evidence of any gas leak, shut down the boiler at once. Find the leak source with bubble test and repair immediately. Do not start boiler again until corrected. Failure to comply could result in severe personal injury, death or substantial property damage.

**▲DANGER** Do not use petroleum-based cleaning or sealing compounds in boiler system. Severe damage to boiler will occur, resulting in substantial property damage.

1. **Check system piping for leaks.** If found, shut down boiler and repair immediately.
2. **Vent air from system** using manual vents. Air in the system will interfere with circulation and cause heat distribution problems and noise.
3. **Inspect vent system** thoroughly for signs of deterioration from corrosion, physical damage or sagging. Verify that masonry chimney liners are in good condition, with no obstructions, and there are no openings into the chimney.

**▲WARNING** Venting system must be sealed gas-tight to prevent flue gas spillage and carbon monoxide emissions. Failure to comply could result in severe personal injury or death.

4. **Check around the boiler for gas odor** following the procedure of Section 7, page 14 of this manual.
5. **Verify operation** using procedures below. Perform checkout procedure in Section 8, page 16, and fill in the “Installation and service certificate”.

### If boiler doesn’t start . . . Check for:

1. Loose connections, blown fuse or service switch off?
2. High limit switch set below boiler water temperature?
3. Thermostat set below room temperature?
4. Gas not turned on at meter or boiler?
5. Incoming gas pressure less than:  
5” w.c. for natural gas? 11” w.c. for propane gas?
6. If none of the above corrects the problem, see “Troubleshooting,” page 25 of this manual.

### Verify operation

#### Check burner flame — Pilot burner

**Proper pilot flame (see Figure 10):**

1. Blue flame.
2. Inner cone engulfing pilot flame sensor.
3. Pilot flame sensor glowing cherry red.

**Improper pilot flame:**

1. Overfired — Large flame lifting or blowing past pilot flame sensor.
2. Underfired — Small flame. Inner cone not engulfing pilot flame sensor.
3. Lack of primary air — Yellow flame tip.
4. Incorrectly heated pilot flame sensor.

#### Check burner flames — Main burner

**Proper main burner flame (see Figure 11):**

1. Yellow-orange streaks may appear (caused by dust). (The GWS-090E will operate at low fire for the first 60 seconds.)

**Improper main burner flame:**

1. Overfired — Large flames.
2. Underfired — Small flames.
3. Lack of primary air — Yellow tipping on flames (sooting will occur).

**Figure 10** Typical pilot burner flame

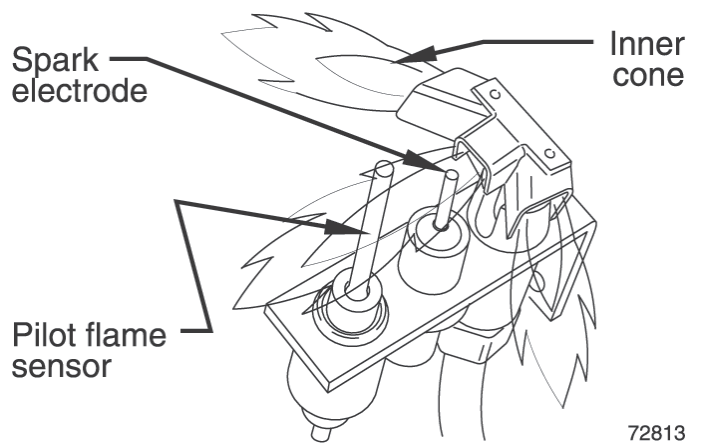

**Figure 11** Typical main burner flame

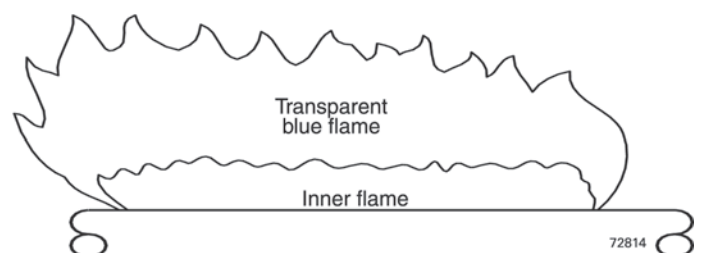

## 8 Checkout procedure

- Boiler and heat distribution units filled with water?
- Automatic air vent, if used, open one full turn?
- Air purged from system?
- Air purged from gas piping? Piping checked for leaks?
- Correctly sized manifold orifices installed? Refer to manual Section 2 to check size and fuel type.

**⚠ DANGER** Correctly sized manifold orifices must be used. Failure to do so will cause severe personal injury, death or substantial property damage.

- Followed operating instructions on boiler or in manual Section 9 for proper start-up?
- Verify that the boiler switches to high fire after 60 seconds of main flame operation.
- Proper burner flame observed at high fire? Refer to Check burner flame, manual Section 7.
- Test limit control — While burners are operating, move indicator on limit control below actual boiler water temperature. Burners should go off while circulator continues to operate. Raise setting on limit control above boiler water temperature and burners should reignite.
- Test additional field-installed controls — If boiler has a low water cutoff, additional high limit or other controls, test for operation as outlined by manufacturer. Burners should be operating and should go off when controls are tested. When controls are restored, burners should reignite.
- Test ignition system safety device:
  - a. Connect manometer to outlet side of gas valve. Start boiler, allowing for normal start-up cycle to occur and main burners to ignite. With main burners on, manually shut off gas supply at manual main shutoff gas valve. Burners should go off. Open manual main shutoff gas valve. Manometer should confirm there is no gas flow. Pilot will relight, flame sensing element will sense pilot flame and main burners reignite.

- Set limit control(s) to system temperature requirements. Adjust balancing valves and controls to provide design temperature to system.
- For multiple zones, adjust flow so it is about the same in each zone.
- Verify thermostat heat anticipator (if available) set properly? Refer to Field wiring, manual Section 6, Thermostat(s).
- Cycle boiler with thermostat — Raise to highest setting and verify boiler goes through normal start-up cycle. Lower to lowest setting and verify boiler goes off.
- Measure natural gas input:
  - a. Operate boiler 10 minutes.
  - b. Turn off other appliances.
  - c. At natural gas meter, measure time (in seconds) required to use one cubic foot of gas.
  - d. Calculate gas input:
 
$$\frac{3600 \times 1000}{\text{number of seconds from step c}} = \text{Btuh}$$
  - e. Btuh calculated should approximate input rating on boiler rating label.
- Check manifold gas pressure by connecting manometer to downstream test tapping on main gas valve. Manifold pressure for natural gas should be 3.5" w.c. and for propane gas should be 10" w.c.
- Observe several operating cycles for proper operation.
- Set room thermostat to desired room temperature.
- Fill in Installation and service certificate below?
- Review all instructions shipped with this boiler with owner or maintenance person. Return instructions to envelope and give to owner or place in pocket inside front panel in boiler.

### Installation and service certificate

Boiler model \_\_\_\_\_ Series \_\_\_\_\_

CP number \_\_\_\_\_ Date installed \_\_\_\_\_

Measured Btuh input \_\_\_\_\_

- Installation instructions have been followed.
- Checkout sequence has been performed.
- Above information is certified to be correct.
- Information received and left with owner/maintenance person.

Installer \_\_\_\_\_ (company) \_\_\_\_\_ (address) \_\_\_\_\_ (phone)

\_\_\_\_\_  
(installer's signature)



## 9 Sequence of operation



Follow all procedures given in this manual and “Operating Instructions”, Section 10, page 19 and on the inside of the boiler jacket panel, when operating the boiler. Failure to do so could result in severe personal injury, death or substantial property damage.

1. Raise room thermostat to call for heat.
2. Inducer and circulator energize. After pressure switch proves proper airflow, control module initiates 10-second prepurge.
3. Control module sparks the pilot and opens pilot valve in main gas valve.
  - a. If pilot does not light within 15 seconds, pilot valve is closed and spark generator is turned off. Control module initiates a 15-second postpurge, then starts a new cycle.
  - b. If pilot does light and control module senses flame current, spark generator is turned off and main valve opens.
4. The GWS-090E timer relay delays high fire for the first 60 seconds of main flame.
5. During main burner operation:
  - a. Control module monitors pilot flame current. If signal is lost, main valve closes, spark generator activates and sequence returns to step 4.
  - b. If power is interrupted, control system shuts off pilot and main gas valves and restarts at step 1 when power is restored.
6. In the event the limit control shuts down the boiler — The control module closes the gas valve, but keeps the inducer operating for 15-second postpurge. — The circulator continues to operate.
7. Lower room thermostat setting to stop call for heat. Thermostat is satisfied — Pilot and main gas valves are closed — Inducer operates for 15-second postpurge — Circulator is shut off.
8. Boiler is now in the off cycle.
9. Repeat steps 1 through 6 several times to verify operation.
10. Return the thermostat to normal setting.
11. Set thermostat heat anticipator setting per wiring diagram, page 18.

**Figure 12** GWS-090E control module sequence of operation (based on indicator light status)

Steps (Following step 8, cycle goes back to step 1.)	CALL FOR HEAT?	POWER	TSTAT CIRC	LIMIT	PRESS SWITCH	FLAME	Timing
<b>1. Standby</b> · Waiting for call for heat	NO	●	○	○	○	○	—
<b>2. Call for heat</b> · Circulator on · Blower on	YES	●	●	○	○	○	—
<b>3. Limit circuit</b> · Limit controls closed · Block switch contacts closed	YES	●	●	●	○	○	—
<b>4. Pressure circuit</b> · Pressure switch contacts closed · Prepurge for 10 seconds	YES	●	●	●	●	○	35 sec
<b>5. Pilot flame proven *</b> · Gas valve open · Pilot remains on · Boiler producing heat	YES	●	●	●	●	●	15 sec
<b>6. Limit cycle</b> · Limit circuit open · Gas valve closed	YES	●	●	○	○	○	—
<b>7. Flame outage *</b> · Flame out · Boiler recycles	YES	●	●	●	●	○	—
<b>8. Thermostat satisfied</b> · Circulator off · Blower postpurge	NO	●	○	●	●	○	15 sec
<b>9. Circulator exercise routine</b> · Circulator turns on for 30 seconds if boiler not operated for 30 days	NO	●	○	○	○	○	30 sec

\* If pilot flame is not proven in 15 seconds, control module will flash the FLAME light, but will continue indefinitely with attempts to light the pilot burner. The control module will not lockout on a failure to establish flame. It will lockout if line voltage polarity is reversed, stray voltage is sensed on thermostat line, pressure switch sticks closed or fails to make within 5 minutes or if flame is sensed when it shouldn't be there. The boiler will reset after these lockouts if any of the following occurs:  
 • 1 hour waiting period      • Opening and closing of thermostat circuit      • Removal of 120 VAC power for at least 45 seconds.

# 9 Sequence of operation *continued*

Figure 13 Wiring diagram — GWS-090E boilers

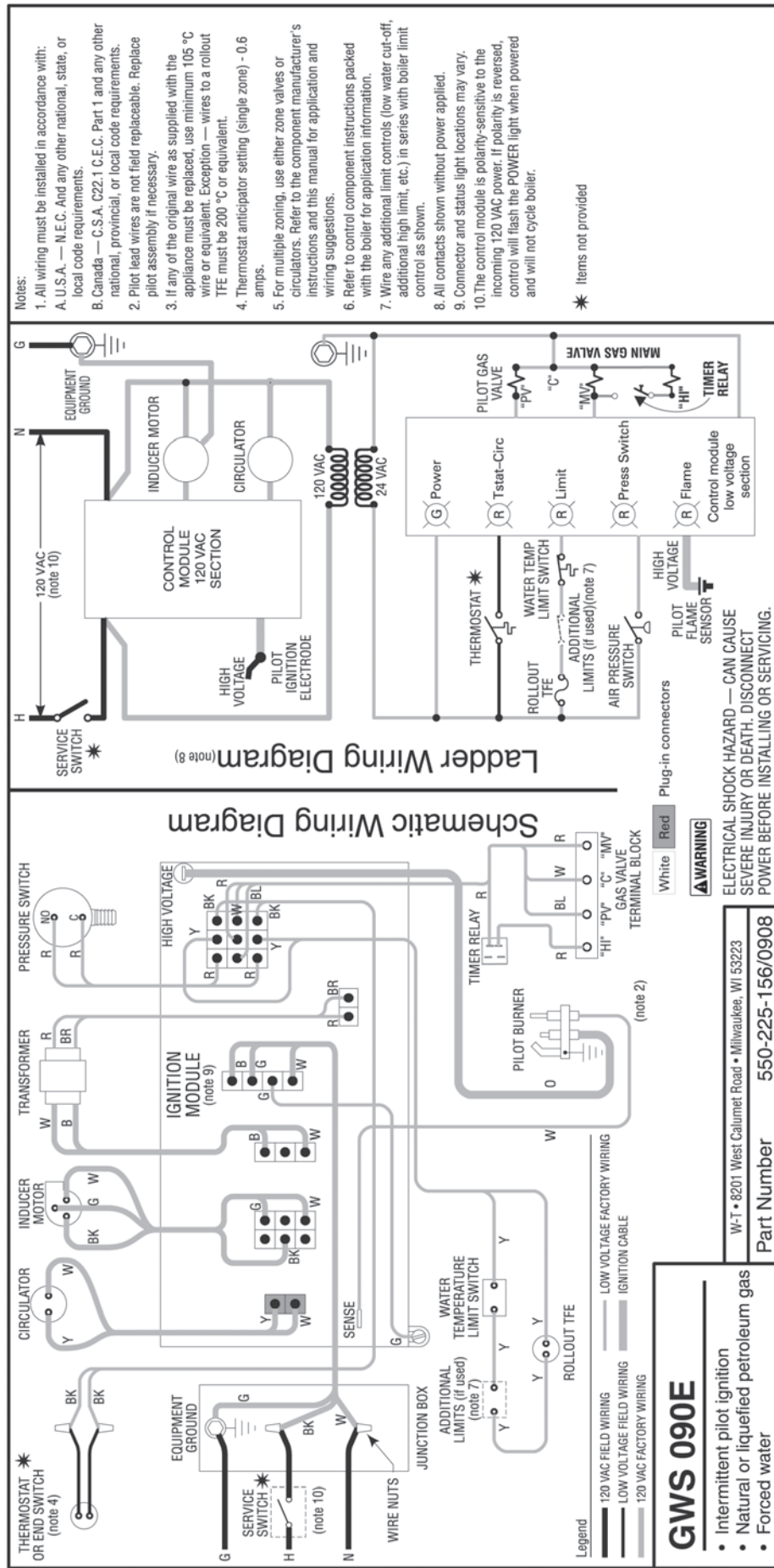

# 10 Operating instructions

## FOR YOUR SAFETY READ BEFORE OPERATING



**WARNING** If you do not follow these instructions exactly, a fire or explosion may result causing property damage, personal injury or loss of life.

- A. This appliance does not have a pilot. It is equipped with an ignition device which automatically lights the burner. Do not try to light the burner by hand.
- B. **BEFORE OPERATING**, smell all around the appliance area for gas. Be sure to smell next to the floor because some gas is heavier than air and will settle on the floor. See below.
- C. Use only your hand to turn the gas control knob. Never use tools. If the knob will not turn by hand, don't try to repair it, call a qualified service technician. Force or attempted repair may result in a fire or explosion.
- D. Do not use this appliance if any part has been under water. Immediately call a qualified service technician to inspect the appliance and to replace any part of the control system and any gas control, which has been under water.

### WHAT TO DO IF YOU SMELL GAS

- Do not try to light any appliance.
- Do not touch any electric switch; do not use any phone in your building.
- Immediately call your gas supplier from a neighbor's phone. Follow the gas supplier's instructions.
- If you cannot reach your gas supplier, call the fire department.

## OPERATING INSTRUCTIONS

1. **STOP!** Read the safety information above on this label.
2. Set the thermostat to lowest setting.
3. Turn off all electrical power to the appliance.
4. Remove jacket front panel.
5. This appliance is equipped with an ignition device which automatically lights the burner. Do not try to light the burner by hand.
6. Turn Gas control knob clockwise ↻ to "OFF."
7. Wait five (5) minutes to clear out any gas. Then smell for gas, including near the floor. If you smell gas, **STOP!** Follow "B" in the safety information above. If you don't smell gas, go to the next step.
8. Turn Gas control knob counterclockwise ↺ to "ON."
9. Turn on all electric power to the appliance.
10. Set thermostat to desired setting.
11. If the appliance will not operate, follow the instructions "TO TURN OFF GAS TO APPLIANCE" below and call your service technician or gas supplier.
12. Replace jacket front panel.

Honeywell  
VR8204 or  
VR8304  
Gas valve

Position indicator  
(shown in "ON" position)

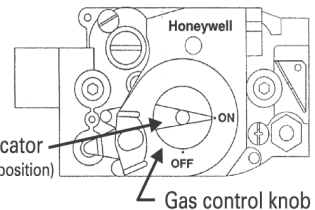

Honeywell  
VR8204Q  
Gas valve

Position indicator  
(shown in "ON" position)

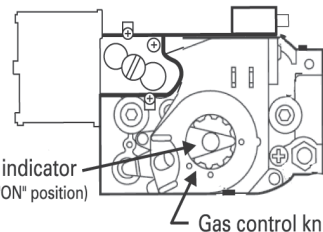

## TO TURN OFF GAS TO THE APPLIANCE

1. Set thermostat to lowest setting.
2. Turn off all electric power to the appliance if service is to be performed.
3. Remove jacket front panel.
4. Turn Gas control knob clockwise ↻ to "OFF." Do not force.
5. Replace jacket front panel.

550-223-237(1108)

# 11 Service and maintenance

**Table 6** Service and maintenance schedules (service technician and user)

<b>Service technician</b> (see following pages for instructions)	<b>Owner maintenance</b> (see User's Information Manual for instructions)
ANNUAL START-UP	<ul style="list-style-type: none"> <li><input type="checkbox"/> <b>Daily</b> <ul style="list-style-type: none"> <li>Check boiler area</li> <li>Check boiler pressure/temperature gauge</li> <li>Check air openings</li> </ul> </li> </ul>
	<ul style="list-style-type: none"> <li><input type="checkbox"/> <b>Monthly</b> <ul style="list-style-type: none"> <li>Check boiler piping</li> <li>Check venting system</li> <li>Check condensate drain system</li> <li>Check boiler relief valve</li> <li>Check automatic air vents (if used)</li> <li>Check pilot and main burner flames</li> <li>Check and clean vent termination &amp; air intake screens</li> </ul> </li> </ul>
	<ul style="list-style-type: none"> <li><input type="checkbox"/> <b>Periodically</b> <ul style="list-style-type: none"> <li>Test low water cutoff (if used)</li> <li>Oil inducer motor</li> </ul> </li> </ul>
	<ul style="list-style-type: none"> <li><input type="checkbox"/> <b>Every 6 months</b> <ul style="list-style-type: none"> <li>Operate relief valve</li> </ul> </li> </ul>
	<ul style="list-style-type: none"> <li><input type="checkbox"/> <b>End of season</b> <ul style="list-style-type: none"> <li>Shut down procedure</li> </ul> </li> </ul>
	<ul style="list-style-type: none"> <li><input type="checkbox"/> <b>Inspect:</b> <ul style="list-style-type: none"> <li>Reported problems</li> <li>Boiler area</li> <li>Air openings</li> <li>Flue gas vent system</li> <li>Pilot and main burner flames</li> <li>Water piping</li> <li>Boiler heating surfaces</li> <li>Burners, base and inlet air box</li> <li>Condensate drain system</li> </ul> </li> </ul>
	<ul style="list-style-type: none"> <li><input type="checkbox"/> <b>Service:</b> <ul style="list-style-type: none"> <li>Inducer motor</li> <li>Oiled-bearing circulators</li> </ul> </li> </ul>
	<ul style="list-style-type: none"> <li><input type="checkbox"/> <b>Start-up:</b> <ul style="list-style-type: none"> <li>Perform start-up per manual</li> </ul> </li> </ul>
	<ul style="list-style-type: none"> <li><input type="checkbox"/> <b>Check/test:</b> <ul style="list-style-type: none"> <li>Gas piping</li> <li>Cold fill and operating pressures</li> <li>Air vents and air elimination</li> <li>Limit controls and cutoffs</li> <li>Expansion tank</li> <li>Boiler relief valve</li> </ul> </li> </ul>
	<ul style="list-style-type: none"> <li><input type="checkbox"/> <b>Review:</b> <ul style="list-style-type: none"> <li>Review with owner</li> </ul> </li> </ul>
<ul style="list-style-type: none"> <li><input type="checkbox"/> <b>Cleaning boiler heating surfaces</b></li> </ul>	

**⚠ WARNING** Follow the “Service and maintenance” procedures given throughout this manual and in component literature shipped with the boiler. See “Read this first” on page 2. Failure to perform the service and maintenance could result in damage to the boiler or system. Failure to follow the directions in this manual and component literature could result in severe personal injury, death or substantial property damage.

# 11 Service and maintenance *continued*

## Handling ceramic fiber and fiberglass materials

### REMOVAL OF COMBUSTION CHAMBER LINING OR BASE PANELS

#### **WARNING**

The combustion chamber lining or base insulation panels in this product contain ceramic fiber materials. Ceramic fibers can be converted to cristobalite in very high temperature applications. The International Agency for Research on Cancer (IARC) has concluded, “Crystalline silica inhaled in the form of quartz or cristobalite from occupational sources is carcinogenic to humans (Group 1).”:

- Avoid breathing dust and contact with skin and eyes.
  - Use NIOSH certified dust respirator (N95). This type of respirator is based on the OSHA requirements for cristobalite at the time this document was written. Other types of respirators may be needed depending on the job site conditions. Current NIOSH recommendations can be found on the NIOSH web site at <http://www.cdc.gov/niosh/homepage.html>. NIOSH approved respirators, manufacturers, and phone numbers are also listed on this web site.
  - Wear long-sleeved, loose fitting clothing, gloves, and eye protection.
- Apply enough water to the combustion chamber lining or base insulation to prevent airborne dust.
- Remove combustion chamber lining or base insulation from the boiler and place it in a plastic bag for disposal.
- Wash potentially contaminated clothes separately from other clothing. Rinse clothes washer thoroughly.

#### **NIOSH stated First Aid.**

- Eye: Irrigate immediately
- Breathing: Fresh air.

### REMOVAL OF FIBERGLASS WOOL — OR —

### INSTALLATION OF FIBERGLASS WOOL, COMBUSTION CHAMBER LINING OR BASE PANELS:

#### **WARNING**

This product contains fiberglass jacket insulation and ceramic fiber materials in combustion chamber lining or base panels in gas fired products. Airborne fibers from these materials have been listed by the State of California as a possible cause of cancer through inhalation.

- Avoid breathing dust and contact with skin and eyes.
  - Use NIOSH certified dust respirator (N95). This type of respirator is based on the OSHA requirements for fiberglass wool at the time this document was written. Other types of respirators may be needed depending on the job site conditions. Current NIOSH recommendations can be found on the NIOSH web site at <http://www.cdc.gov/niosh/homepage.html>. NIOSH approved respirators, manufacturers, and phone numbers are also listed on this web site.
  - Wear long-sleeved, loose fitting clothing, gloves, and eye protection.
- Operations such as sawing, blowing, tear out, and spraying may generate airborne fiber concentration requiring additional protection.
- Wash potentially contaminated clothes separately from other clothing. Rinse clothes washer thoroughly.

#### **NIOSH stated First Aid.**

- Eye: Irrigate immediately
- Breathing: Fresh air.

# 11 Service and maintenance *continued*

**WARNING** The boiler contains ceramic fiber and fiberglass materials. Use care when handling these materials per instructions on page 21 of this manual. Failure to comply could result in severe personal injury.

## □ Inspect . . . . .

### Reported problems

Inspect any problems reported by owner and correct before proceeding.

### Boiler area

1. Verify that boiler area is free of any combustible materials, gasoline and other flammable vapors and liquids.
2. Verify that boiler area (and air intake) is free of any of the contaminants listed in Table 3 on page 5 of this manual. If any of these are present in the boiler intake air vicinity, they must be removed.

### Air openings

1. Verify that combustion and ventilation air openings to the boiler room and/or building are open and unobstructed. Check operation and wiring of automatic combustion air dampers, if used.
2. Verify that boiler vent discharge and air intake are clean and free of obstructions.

### Flue gas vent system

1. Visually inspect entire flue gas venting system for blockage, deterioration or leakage. Repair any joints that show signs of leakage in accordance with vent manufacturer's instructions.

**WARNING** Failure to inspect for the above conditions and have them repaired can result in severe personal injury or death.

### Pilot and main burner flames

1. Visually inspect pilot burner and main burner flames as directed under Section 7, page 15 of this manual.

### Water piping

1. Check the boiler interior piping and all system piping for signs of leaks.
2. Repair any leaks before proceeding.

**WARNING** Electrical shock hazard — Turn off power to the boiler before any service operation on the boiler except as noted otherwise in this instruction manual. Failure to turn off electrical power could result in electrical shock, causing severe personal injury or death.

**DANGER** Do not use petroleum-based cleaning or sealing compounds in boiler system. Severe damage to boiler will occur, resulting in substantial property damage.

**WARNING** Eliminate all system or boiler leaks. Continual fresh makeup water will reduce boiler life. Minerals can build up in sections, reducing heat transfer, overheating cast iron, and causing section failure. Leaking water may also cause severe property damage.

### Boiler heating surfaces

1. Disconnect the vent pipe at the boiler inducer outlet connection after turning off power to the boiler.

2. Use a bright light to inspect the flue pipe interior and inducer interior.
3. Inspect the boiler vent outlet area and heating surfaces by looking through the opening.
4. If the vent pipe or inducer interior show evidence of soot, follow Cleaning boiler heating surfaces in this manual section to remove the flue collector and clean the boiler if necessary after close inspection of boiler heating surfaces. If there is evidence of rusty scale deposits, check the water piping and control system to make sure the boiler return water temperature is properly maintained (per this manual).
5. Reconnect vent to inducer outlet and replace all boiler components before returning to service.
6. Check inside and around boiler for evidence of any leaks from the boiler. If found, locate source of leaks and repair.

### Burners and base

1. After turning off power to the boiler, remove the inlet air box top panel (Figure 16, item 13, page 34).
2. Inspect gasket (Figure 16, item 14, page 34).
2. Inspect burners and all other components in the inlet air box and boiler base.
3. If burners must be cleaned, access the burner assembly by first removing the burner baffle (Figure 16, item 4, page 34). Then remove the screws securing the burner tray to the manifold. Slide the burner tray out. Then brush and vacuum the burners thoroughly, making sure all ports are free of debris.
4. Inspect the base insulation. Verify that the insulation is intact and secure against all four sides of the base.

**WARNING** The boiler contains ceramic fiber and fiberglass materials. Use care when handling these materials per instructions on page 21 of this manual. Failure to comply could result in severe personal injury.

**WARNING** If insulation is damaged or displaced, do not operate the boiler. Replace or reposition insulation as necessary. Failure to replace damaged insulation can result in a fire hazard, causing severe personal injury, death or substantial property damage.

5. Replace inlet air box top panel.

**WARNING** Do not operate boiler without inlet air box top panel secured in place. Failure to comply could result in severe personal injury, death or substantial property damage.

### Condensate drain system

1. If vent system is equipped with a condensate drain, check the hose and connections for tightness.
2. Verify the hose is unobstructed and in good condition and that condensate can flow freely. Replace hose if necessary.

# 11 Service and maintenance *continued*

## □ Service . . . . .

### Inducer motor

1. With boiler power OFF, place a few drops of S.A.E. 20 motor oil in each of the two motor oiling cups.

**⚠WARNING** Use only S.A.E. 20 motor oil to lubricate inducer motor. Do not use universal household oils. Motor could be damaged, resulting in possible severe property damage.

### Oiled-bearing circulators

1. The circulator shipped with the GWS-090E boiler is water-lubricated. No oiling is required.
2. Check other circulators in the system. Oil any circulators requiring oil, following circulator manufacturer's instructions. Over-oiling will damage the circulator.

## □ Start-up . . . . .

1. Perform start-up procedures of Section 7, pages 14–15, including procedure to verify operation of burners on page 15.
2. Verify cold fill pressure is correct and that fill system is working properly.
3. Verify antifreeze level (if used) is at the right concentration and that inhibitor level is correct.
4. Check gas piping, per manual Section 5, page 12, and section 7, page 14, verifying no indications of leakage and all piping and connections are in good condition.
5. Read "Operating instructions", Section 10, page 19.
6. Start the boiler following "Operating instructions", Section 10, page 19.

## □ Check/test . . . . .

### Gas piping

1. Sniff near floor and around boiler area for any indication of a gas leak.
2. Test gas piping using bubble test, per Section 5, page 12 of this manual, if there is any indication of a leak.

### Cold fill and operating pressures

1. While the system is cold, note the pressure reading on the boiler pressure/temperature gauge. Verify that cold fill pressure is correct.
2. Watch the pressure as the boiler and system heat up to ensure pressure rise is normal. Too high a rise would indicate a waterlogged or undersized expansion tank.

### Air vents and air elimination

1. Inspect automatic air vents (if used). Also inspect air separators to ensure they are operational.
2. The cap must be unscrewed one turn to allow air to escape.
3. If the air vent is leaking, remove cap and briefly push valve — then release to clean the valve seat.
4. Replace cap by twisting all the way onto valve and then unscrewing one turn.

### Limit controls and cutoffs

1. Inspect and test the boiler limit control. Verify operation by turning control set point below boiler temperature. Boiler should cycle off. Return dial to original setting.
2. Inspect and test additional limit controls or low water cutoffs installed on system.

### Expansion tank

1. Expansion tanks provide space for water to move in and out as the heating system water expands due to temperature increase or contracts as the water cools. Tanks may be open, closed or diaphragm- or bladder-type. See Section 3, page 9 of this manual for suggested locations of expansion tanks and air eliminators.

**Open-type** — located above highest radiator or baseboard unit, usually in the attic or closet. Has a gauge glass and overflow pipe to a drain.

**Closed-type** — welded gas tight and located above boiler. Tank is partially filled with water, leaving an air cushion for expansion.

- Make sure this type of tank is fitted with a tank fitting, such as the B & G Tank-Trol or Taco Taco-Trol. This fitting reduces gravity circulation of air-saturated tank water back to the system and prevents the air from bubbling up through the water as it returns from the system.
- Do not use automatic air vents in systems with closed-type tanks. The air will escape from the system instead of returning to the tank. Eventually, the tank will waterlog and no longer control pressurization. The boiler relief valve will weep frequently.

**Diaphragm- or bladder-type** — welded gas tight with a rubber membrane to separate the tank pressurizing air and the water. May be located at any point in the system, but most often found near the boiler.

- Systems with this type of expansion tank require at least one automatic air vent, preferably located on top of an air eliminator, as shown in examples in manual Section 3, page 10.

2. If relief valve has tended to weep frequently, the expansion tank may be waterlogged or undersized.

**Closed-type tank** — tank is most likely waterlogged. Install a tank fitting if not already installed. Then check fill level per fitting manufacturer's instructions. If fill level is correct, check tank size against manufacturer's instructions. Replace with a larger tank if necessary.

**Diaphragm- or bladder-type** — first, check tank size to be sure it is large enough for the system. If size is too small, add additional tank(s) as necessary to provide sufficient expansion. If tank size is large enough, remove tank from system and check charge pressure (usually 12 psig for residential applications). If tank won't hold pressure, membrane has been damaged. Replace tank.

# 11 Service and maintenance *continued*

## ☐ Check/test . . . . *continued*

### Boiler relief valve

1. Inspect the relief valve and lift the lever to verify flow as in the following warnings, excerpted from a relief valve manufacturer's warning label. Before operating any relief valve, ensure that it is piped with its discharge in a safe area to avoid severe scald potential. Read manual Section 3, page 9, before proceeding further.

**▲WARNING** Safety relief valves should be reinspected **AT LEAST ONCE EVERY THREE YEARS**, by a licensed plumbing contractor or authorized inspection agency, to ensure that the product has not been affected by corrosive water conditions and to ensure that the valve and discharge line have not been altered or tampered with illegally. Certain naturally occurring conditions may corrode the valve or its components over time, rendering the valve inoperative. Such conditions are not detectable unless the valve and its components are physically removed and inspected. This inspection must only be conducted by a plumbing contractor or authorized inspection agency — not by the owner. Failure to reinspect the boiler relief valve as directed could result in unsafe pressure buildup, which can result in severe personal injury, death or substantial property damage.

2. After following the above warning directions, if the relief valve weeps or will not seat properly, replace the relief valve. Ensure that the reason for relief valve weeping is the valve and not over-pressurization of the system due to expansion tank waterlogging or undersizing.

**▲WARNING** Following installation, the valve lever must be operated **AT LEAST ONCE A YEAR** to ensure that waterways are clear. Certain naturally occurring mineral deposits may adhere to the valve, rendering it inoperative. When manually operating the lever, water will discharge and precautions must be taken to avoid contact with hot water and to avoid water damage. Before operating lever, check to see that a discharge line is connected to this valve directing the flow of hot water from the valve to a proper place of disposal otherwise severe personal injury may result. If no water flows, valve is inoperative. Shut down boiler until a new relief valve has been installed.

## ☐ Review with owner

1. Review the User's Information Manual with the owner.
2. Emphasize the need to perform the maintenance schedule specified in the User's Information Manual (and in this manual as well).
3. Remind the owner of the need to call in a licensed contractor should the boiler or system exhibit any unusual behavior.
4. Remind the owner to follow the proper shutdown procedure and to schedule an annual start-up at the beginning of the next heating season.

## ☐ Cleaning boiler heating surfaces

**▲WARNING** The boiler contains ceramic fiber and fiberglass materials. Use care when handling these materials per instructions on page 21 of this manual. Failure to comply could result in severe personal injury.

1. Shut down boiler:
  - Follow "To Turn Off Gas to Appliance" instructions on boiler and "Operating instructions" page 19.
  - Do not drain boiler unless it will be exposed to freezing temperatures. If using antifreeze in system, do not drain.
2. Follow shutdown procedure.
3. Remove venting system connection to boiler.
4. Remove top jacket panel. Turn back insulation.
5. Remove collector box/transition assembly. Clean sealant from assembly and sections.
6. Remove radiation plates hanging between sections.
7. Remove burners from base. Brush and vacuum burners to remove all dust and lint. Verify that all burner ports are free of debris.
8. Place newspapers in base of boiler to collect soot.
9. Clean between sections with wire flue brush.
10. Remove newspaper and soot. Vacuum or brush base and surrounding area.
11. Reinstall radiation plates.
12. Replace collector box/transition assembly. Seal with sealant. Obtain gas-tight seal to prevent flue gas spillage and carbon monoxide emissions, resulting in severe personal injury or death.
13. Replace insulation and jacket top panel.
14. Start up boiler following Section 7, pages 14-15 of this manual and the boiler "Operating instructions", page 19. Excessive sooting indicates improper gas combustion. If found, check for proper combustion and make any necessary adjustments.

### Verifying gas manifold pressure *(downstream of gas valve)*

- a. Natural gas:  
Manifold pressure, high fire: 3.50" w.c.  
Manifold pressure, low fire: 0.90" w.c. while in low fire at start-up (60 seconds)
- b. Propane gas:  
Manifold pressure, high fire: 10.0" w.c.  
Manifold pressure, low fire: 3.50" w.c. while in low fire at start-up (60 seconds)
- c. If necessary, adjust gas pressure on the gas valve as shown below. After adjustments, refer to page 34 to check the flame.

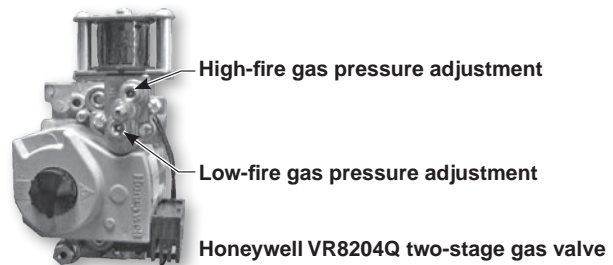



# 12 Troubleshooting

**WARNING** Label all wires prior to disconnection when servicing controls. Wiring errors can cause improper and dangerous operation.

**WARNING** Never jumper (bypass) rollout thermal fuse element or any other device except for momentary testing as outlined in “Troubleshooting” charts, pages 26-32. Severe personal injury, death or substantial property damage can result.

**WARNING** Burner access panel must be in position during boiler operation to prevent momentary flame rollout on ignition of main flame. Severe personal injury or substantial property damage will result.

### Before troubleshooting:

1. Have the following items:
  - a. Voltmeter that can check 120 VAC and 24 VAC.
  - b. Microammeter with a minimum scale range of 0-10.
  - c. Continuity checker.
  - d. U-tube manometer and inclined manometer (with 0 – 2” w.c. range).
2. Check for 120 VAC (minimum 102 VAC to maximum 132 VAC) to boiler.
3. Make sure thermostat is calling for heat and contacts (including appropriate zone controls) are closed. Check for 24 VAC between thermostat wire nuts and ground.

### Check the following:

1. Wire connectors to control module are securely plugged in at module and originating control.
2. Gas pressures:
  - a. With boiler off — 13” w.c. maximum natural or propane gas pressure upstream of gas valve.
  - b. With boiler on:
    - 5” w.c. minimum natural gas pressure or 11” w.c. propane gas pressure upstream of gas valve.
    - 3.5” w.c. minimum natural gas pressure or 10” w.c. propane gas pressure downstream tapping on gas valve — Can be adjusted by regulator on gas valve.
  - c. Verify gas manifold pressure as shown on page 24.

### Check pressure switch setting

**NOTICE** Make sure boiler water temperature is 100 °F or cooler before starting procedure to obtain appropriate readings.

1. See Figure 14 and Table 8.

**Table 8** Pressure switch setpoint (for elevations above 2,000 ft, contact your local supplier for details.)

Boiler model number	Inches W.C.
GWS-090E	1.71

2. Remove both air pressure switch hoses from air pressure switch.
3. Install tees and tubing as shown in Figure 14 to inclined manometer.

**Figure 14** Checking pressure switch

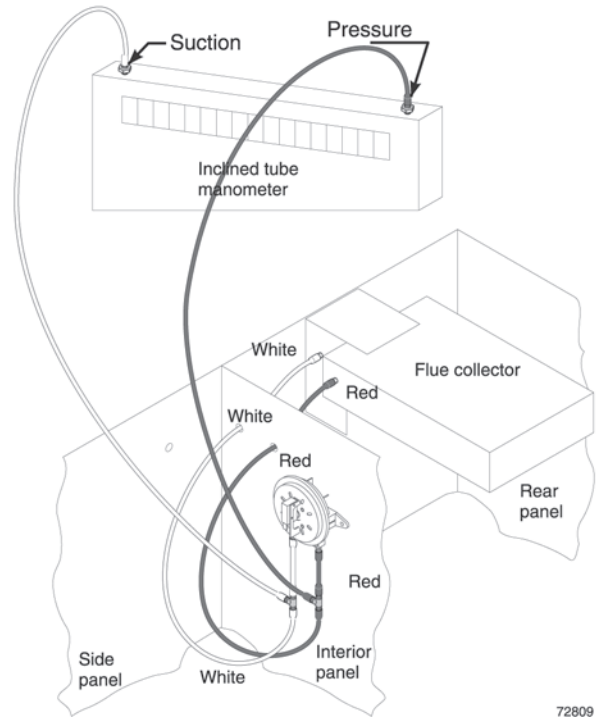

4. Turn off gas valve and set thermostat to call for heat. Inducer will run but burners will not ignite.
5. Check for 24 VAC between both air pressure switch terminals.
6. If manometer reading is above the setpoint of the switch (see Table 8), but there is not 24 VAC between both air pressure switch terminals — replace air pressure switch.

### Troubleshooting air pressure reading

1. If manometer reading is lower than the setpoint of the switch (see Table 8) — check for possible causes:
  - blockage in hoses
  - obstruction in inducer housing outlet
  - loose inducer wheel on motor shaft
  - inducer motor not in proper rpm
  - inducer back plate not sealed properly
  - blockage in block assembly
  - blockage in flue pipe or termination
  - incorrect pressure switch

### Return to normal operation

When pressure reading is correct and air pressure switch is operating properly — remove tees and reinstall hoses to air pressure switch.

**NOTICE** The boiler will not operate correctly unless pressure switch hoses are correctly located. The red hose connects from the right side (negative) hose barb to the flue collector. The white hose connects from the left side (positive) hose barb of the switch to the connector box (between flue collector and inducer) as shown in Figure 14.

# 12 Troubleshooting *continued*

**CHART 1** — Troubleshooting **POWER** light status

— Usually indicates reversed 120 VAC polarity if **POWER** light flashes by itself —

**WARNING** Electrical shock hazard — Wherever you see **TURN OFF POWER**, follow the instructions. Failure to follow instructions could result in severe personal injury, death or substantial property damage.

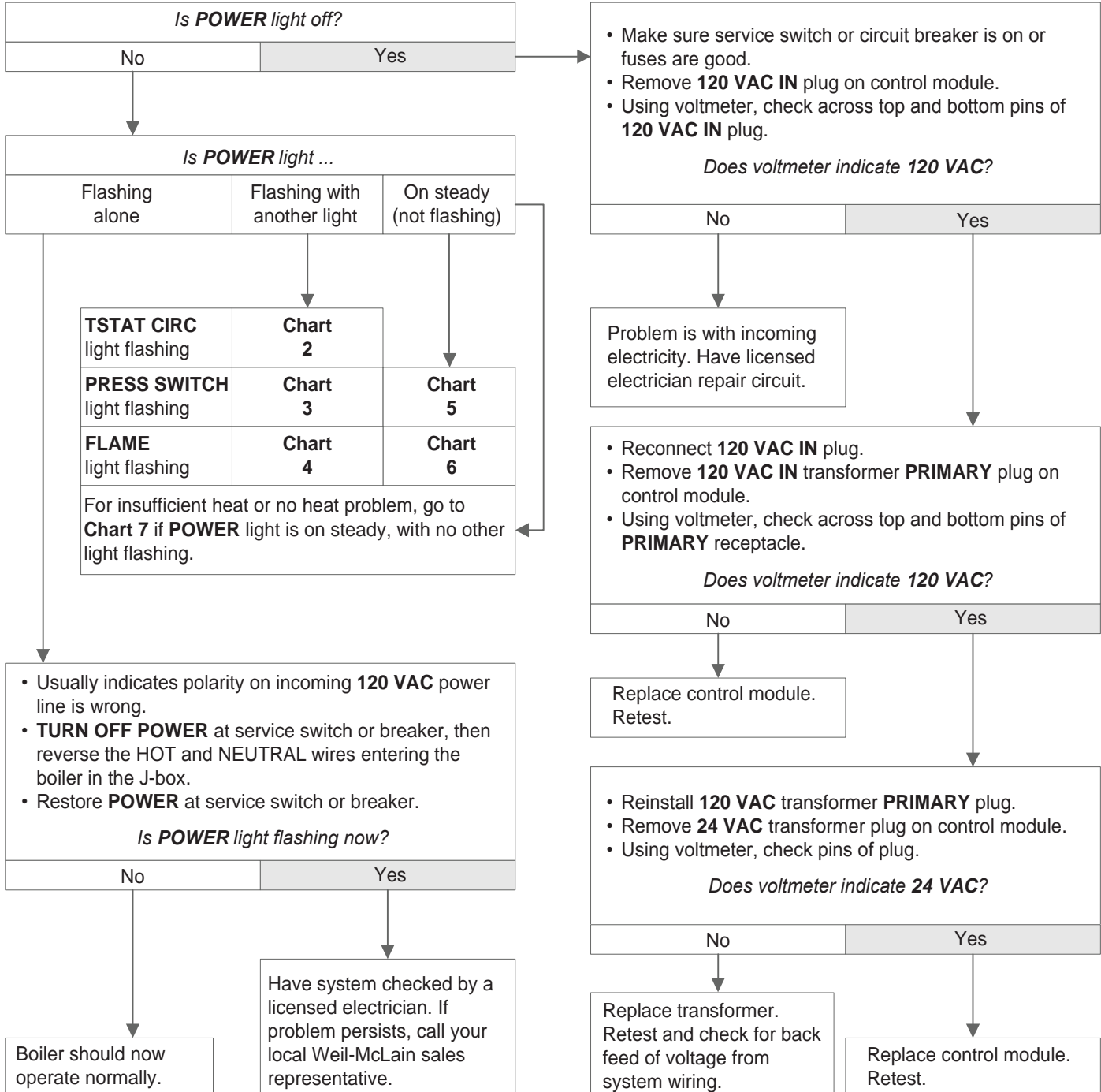

# 12 Troubleshooting *continued*

**CHART 2 — TSTAT CIRC & POWER lights flashing**

— Usually indicates 48 VAC on thermostat circuit (stray voltage) —

**⚠ WARNING** Electrical shock hazard — Wherever you see **TURN OFF POWER**, follow the instructions. Failure to follow instructions could result in severe personal injury, death or substantial property damage.

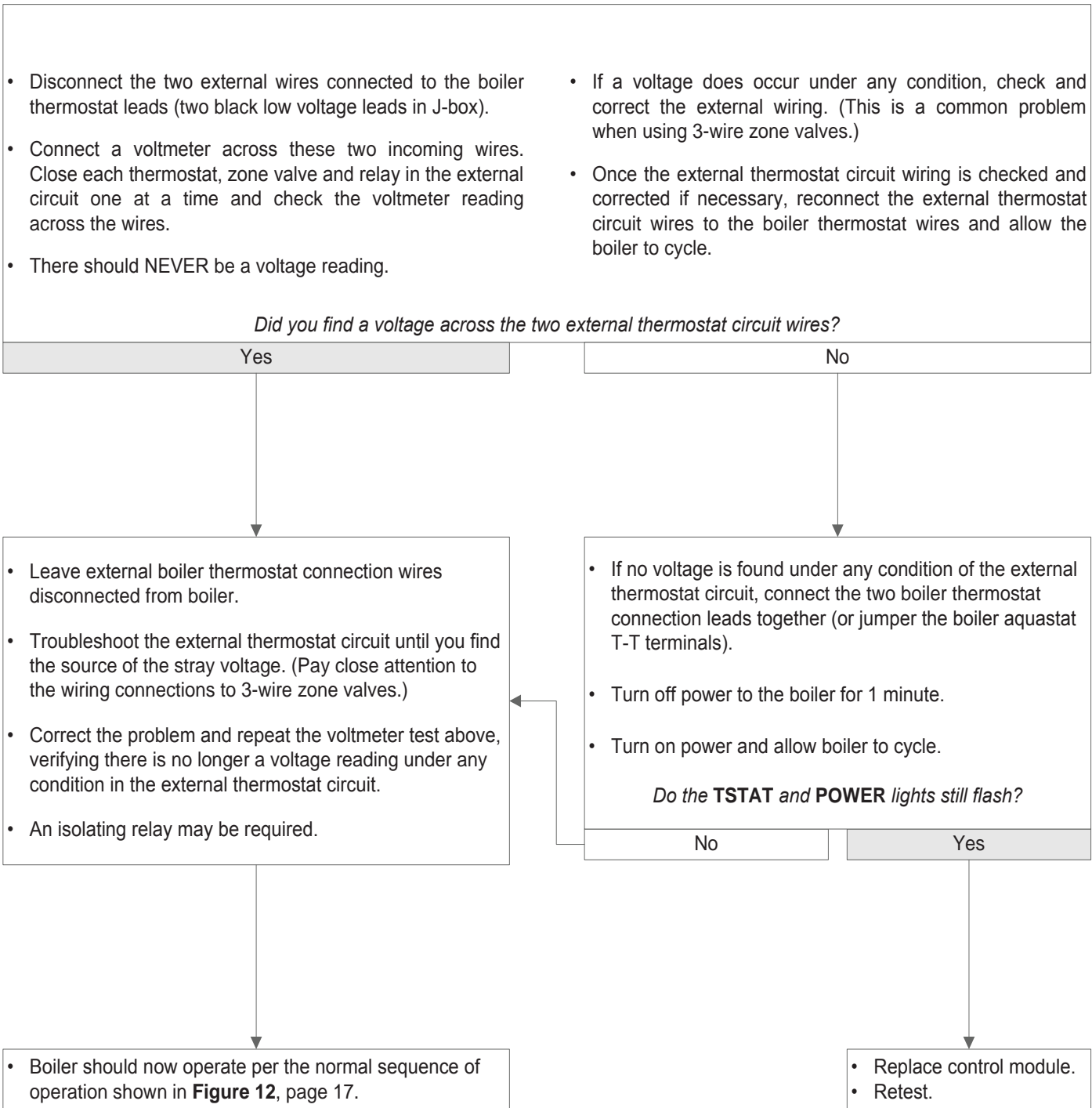

# 12 Troubleshooting *continued*

## CHART 3 — PRESS SWITCH & POWER lights flashing

— Usually indicates pressure switch stuck closed or failed to make within 5 minutes —

**⚠ WARNING** Electrical shock hazard — Wherever you see **TURN OFF POWER**, follow the instructions. Failure to follow instructions could result in severe personal injury, death or substantial property damage.

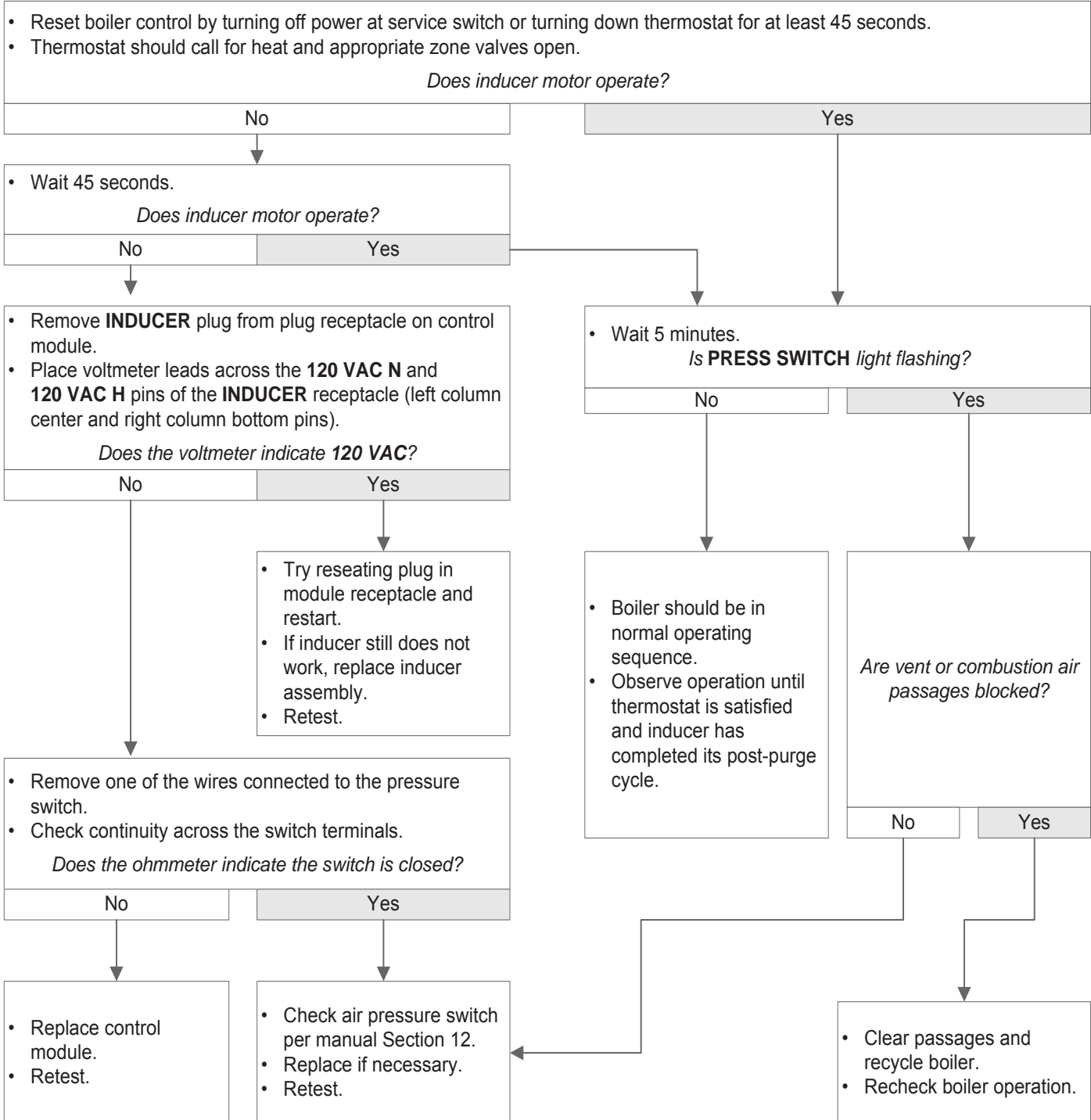

# 12 Troubleshooting *continued*

**CHART 4 — FLAME & POWER lights flashing**

— Usually indicates flame sensed when it shouldn't be there —

**⚠ WARNING** Electrical shock hazard — Wherever you see **TURN OFF POWER**, follow the instructions. Failure to follow instructions could result in severe personal injury, death or substantial property damage.

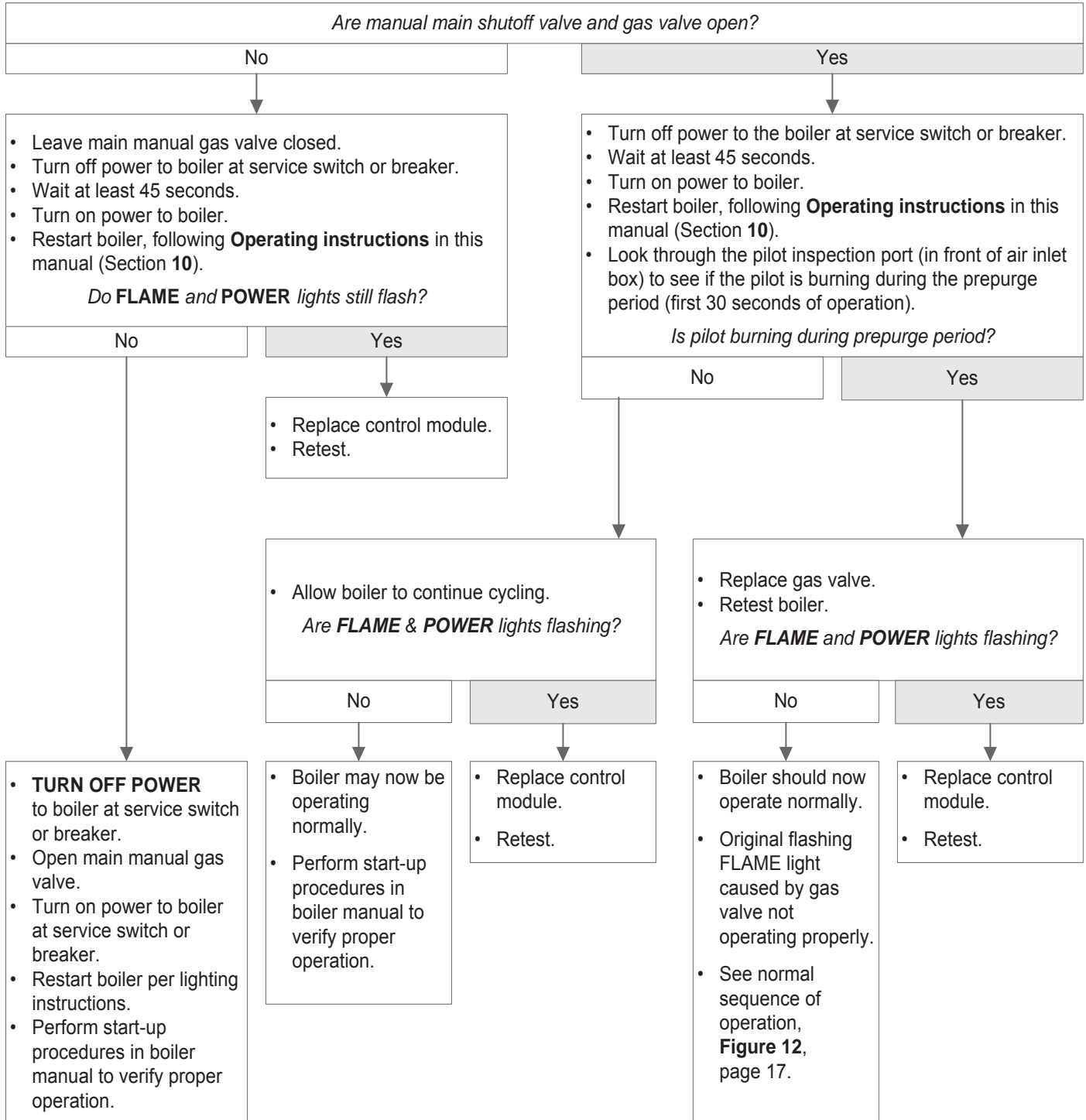

# 12 Troubleshooting *continued*

## CHART 5 — PRESS SWITCH light flashing and POWER light on steady

— Usually indicates pressure switch opened during run cycle —  
 — May also be caused by wind gusts in excess of 31 mph for non-direct vent sidewall-vented boilers —



**WARNING** Electrical shock hazard — Wherever you see **TURN OFF POWER**, follow the instructions. Failure to follow instructions could result in severe personal injury, death or substantial property damage.

- Reset boiler control by turning off power at service switch or turning down thermostat for at least 45 seconds.
- Thermostat should call for heat and appropriate zone valves open.

*Does blower motor operate?*

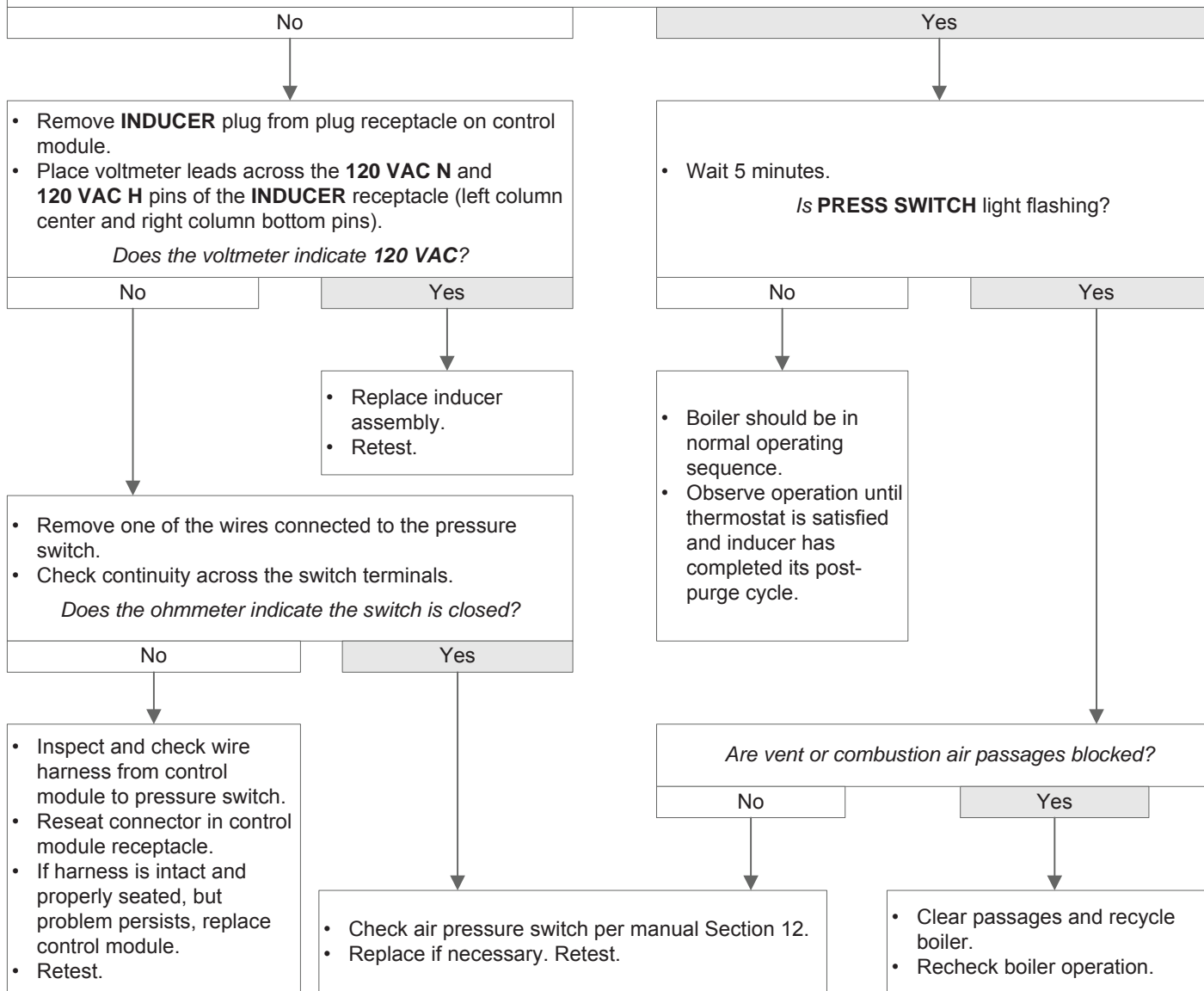

# 12 Troubleshooting *continued*

## CHART 6 — FLAME light flashing and POWER light on steady

### ALSO — Troubleshooting failure to establish main flame

**WARNING** Electrical shock hazard — Wherever you see **TURN OFF POWER**, follow the instructions. Failure to follow instructions could result in severe personal injury, death or substantial property damage.

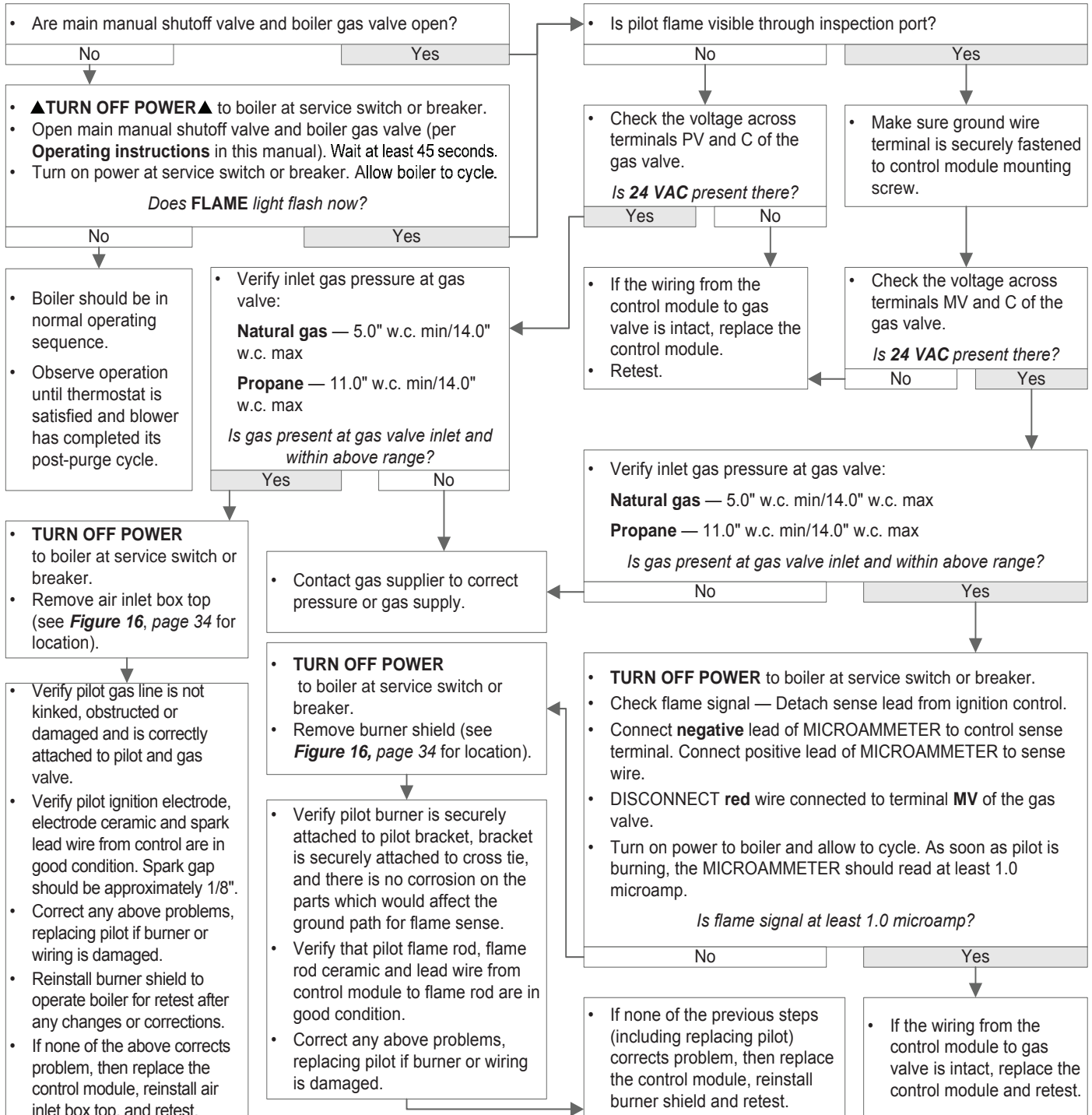

# 12 Troubleshooting *continued*

**CHART 7 — Insufficient heat or no heat to system (POWER light on steady)**

**⚠ WARNING** Electrical shock hazard — Wherever you see **TURN OFF POWER**, follow the instructions. Failure to follow instructions could result in severe personal injury, death or substantial property damage.

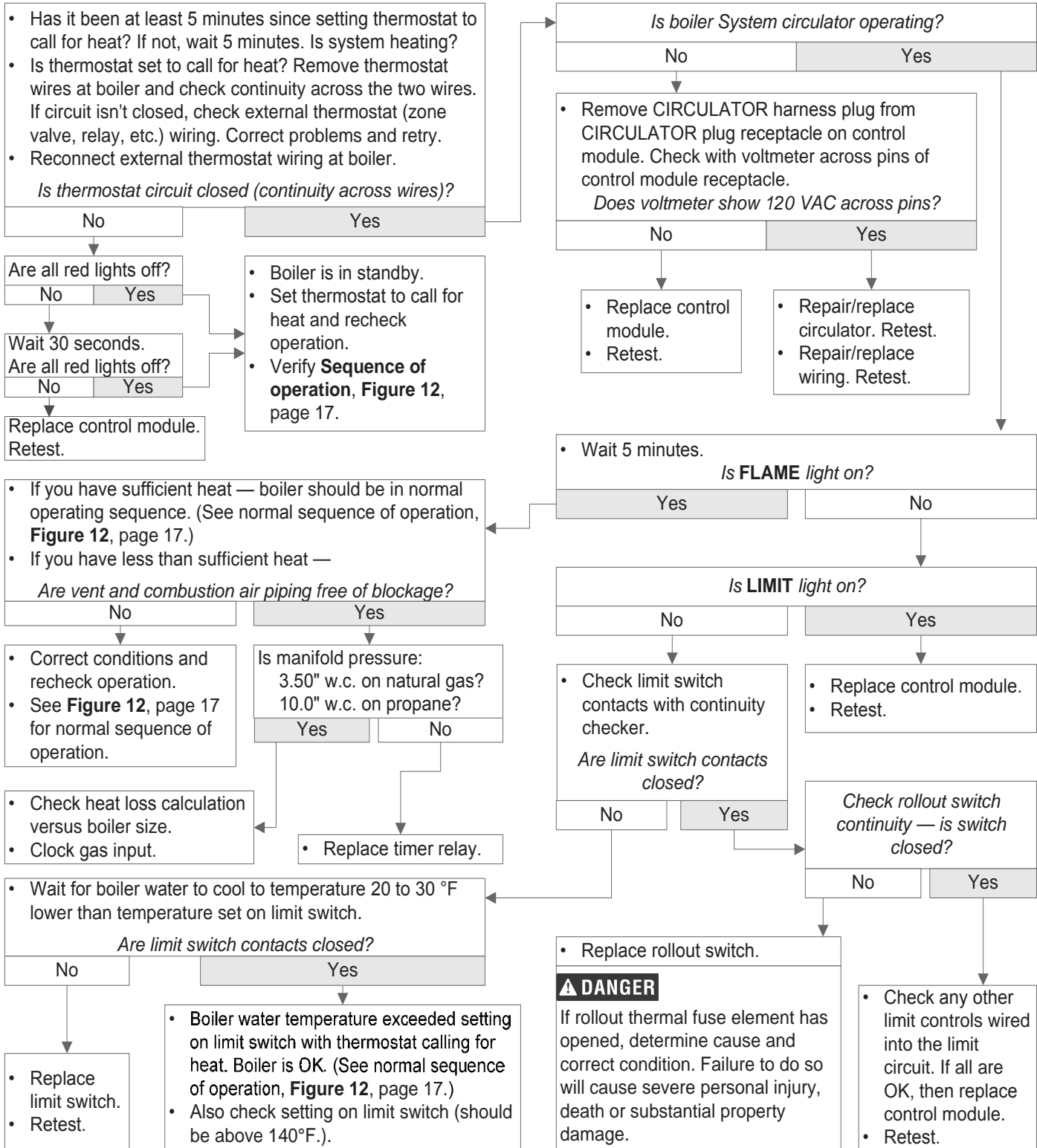



# 13 Replacement parts

**Figure 15** Section assembly, flue collector, draft hood and vent damper

**WARNING** The boiler contains ceramic fiber and fiberglass materials. Use care when handling these materials per instructions on page 21 of this manual. Failure to comply could result in severe personal injury.

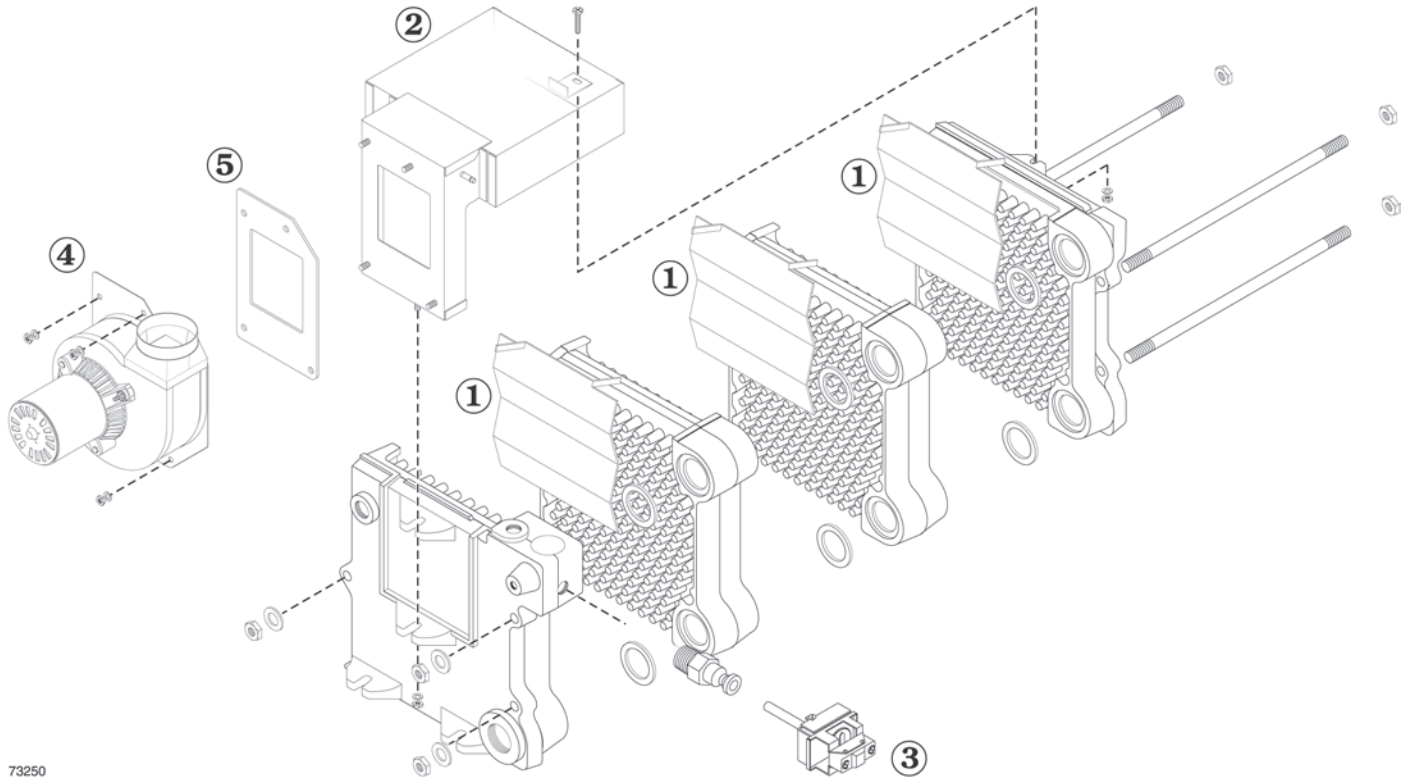

73250

Item number	Description	Part number
not shown	Replacement section assembly	GWS-090E 321-114-346WT
1	Radiation plate (1 per joint)	460-003-700WT
2	Collector hood and transition assembly	GWS-090E 381-354-601WT
3	High limit, 30° differential, with well	Honeywell L4080D1036 White-Rodgers 11B81-3 510-312-250WT
4	Inducer fan assembly kit, includes inducer fan assembly, gasket and nuts	381-356-499WT
5	Gasket, inducer	590-317-627WT

# 13 Replacement parts *continued*

**Figure 16** Base assembly, manifold, orifices and burners

**WARNING** The boiler contains ceramic fiber and fiberglass materials. Use care when handling these materials per instructions on page 21 of this manual. Failure to comply could result in severe personal injury.

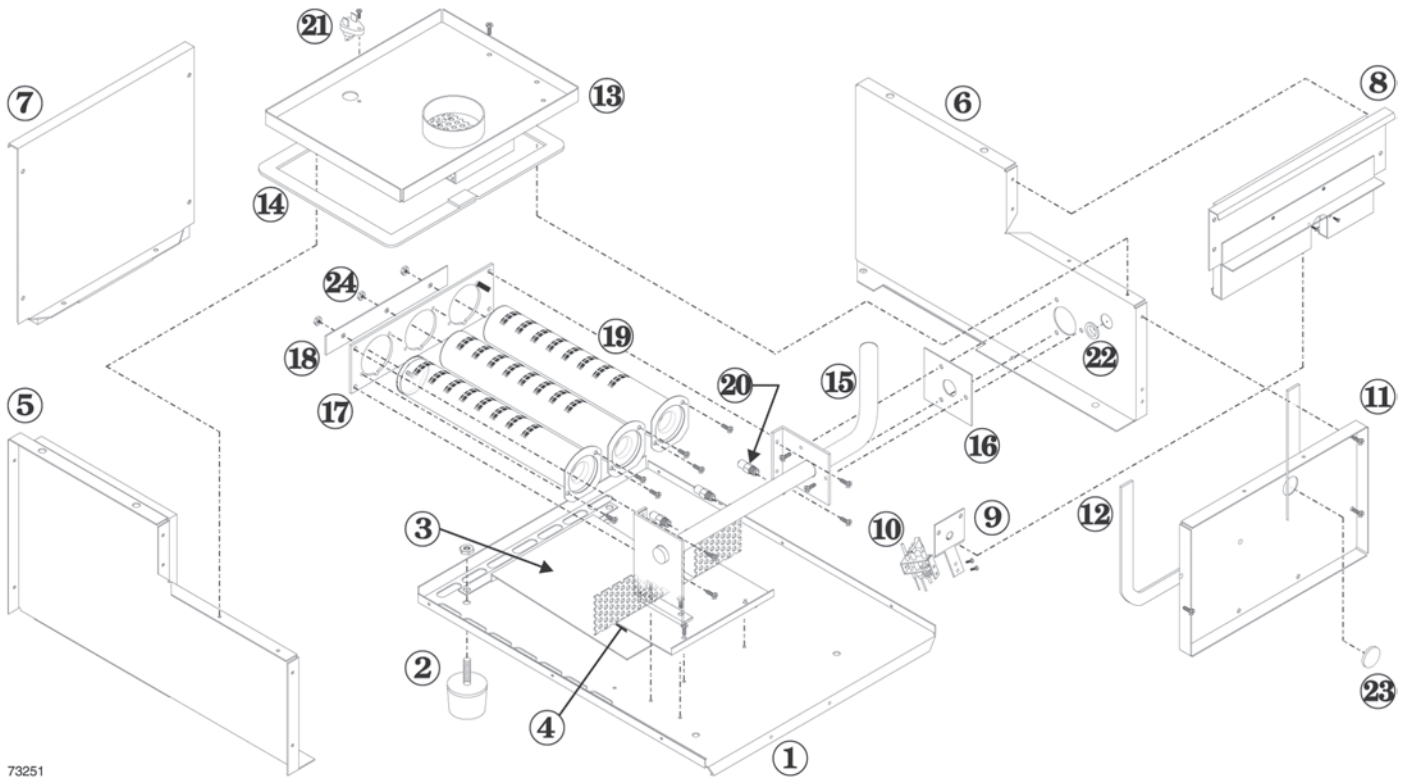

73251

Item	Description	Part number
	Base insulation kit (includes insulation for all base parts shown above plus gasket material needed between block assembly and base)	GWS-090E 381-356-516WT
	Base assembly kit (includes base panels items 1, 2, 3, 4, 5, 6, 7, 8, 11, 13, 22 and 23 plus insulation, Air box gaskets, and hardware)	GWS-090E 381-356-523WT
	Inlet air box top panel kit (includes items 13 and 14)	GWS-090E 381-356-502WT
	Inlet air box front panel kit (includes items 11, 12 and 23)	GWS-090E 381-356-509WT
1	Base pan (in Base assembly)	
2	Boiler leg kit	550-320-219WT
3	Heat shield (in Base assembly)	
4	Burner baffle (in Base assembly)	
5	Base left side panel (in Base assembly)	
6	Base right side panel (in Base assembly)	
7	Base back panel (in Base assembly)	
8	Base front cross-tie assembly (in Base assembly)	
9	Pilot bracket	450-003-689WT
10	Pilot burner assembly — Natural gas Pilot burner assembly — Propane gas	511-330-080WT 511-330-081WT
11	Inlet air box front panel (in Inlet air box front panel kit)	

Item	Description	Part number
12	Inlet air box front panel gasket (use Gasket kit)	
13	Inlet air box top panel (in Inlet air box top panel kit)	
14	Inlet air box top panel gasket (use Gasket kit)	
15	Manifold (per size)	GWS-090E 591-126-723WT
16	Manifold mounting gasket	590-317-406WT
17	Burner mounting panel	GWS-090E 450-003-691WT
18	Rear spacer strip	GWS-090E 550-320-161WT
19	Burner GWS-095 — qty: 3	512-200-076WT
20	Burner orifice — Natural gas, sea level Burner orifice — Propane gas, sea level	560-529-126WT 560-529-111WT
21	Thermal fuse element	512-050-230WT
22	Grommet for sealing pilot tubing/wiring opening to Air box	591-850-064WT
23	Inspection port clear plug	591-491-216WT
24	Hex nut for burner end stud, 5 mm	550-320-170WT
	Gasket (for Air inlet box covers), 8-foot length	590-317-400WT

# 13 Replacement parts *continued*

**Figure 17** Jacket assembly

**WARNING** The boiler contains ceramic fiber and fiberglass materials. Use care when handling these materials per instructions on page 21 of this manual. Failure to comply could result in severe personal injury.

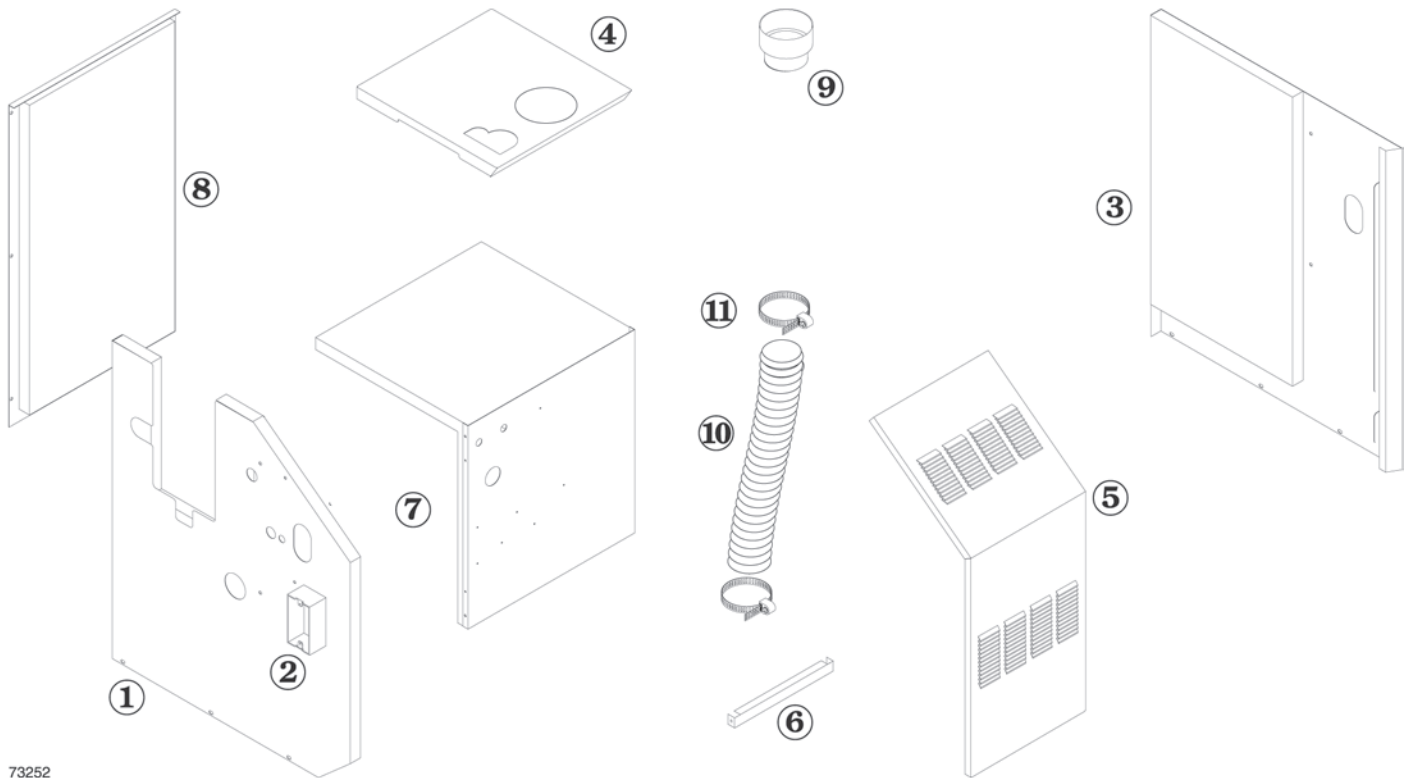

73252

Item number	Description	Part number
1	Jacket panel , left side, with insulation: Natural gas Propane	431-223-490WT 431-223-496WT
2	Junction box, 2 x 4 (available at local supply house)	
3	Jacket panel, right side, with insulation	431-223-488WT
4	Jacket panel, top	GWS-090E 431-223-493WT
5	Jacket panel, door	GWS-090E 431-223-489WT
6	Jacket cross tie, bottom front	GWS-090E 431-223-509WT
7	Jacket panel, interior, with insulation	GWS-090E 431-223-500WT
8	Jacket panel, rear, with insulation	GWS-090E 431-223-446WT
9	Air inlet fitting	560-907-635WT
10	Inlet air hose	562-302-575WT
11	Hose clamp, 3"	591-850-068WT

## 13 Replacement parts *continued*

**Figure 18** Trim assembly

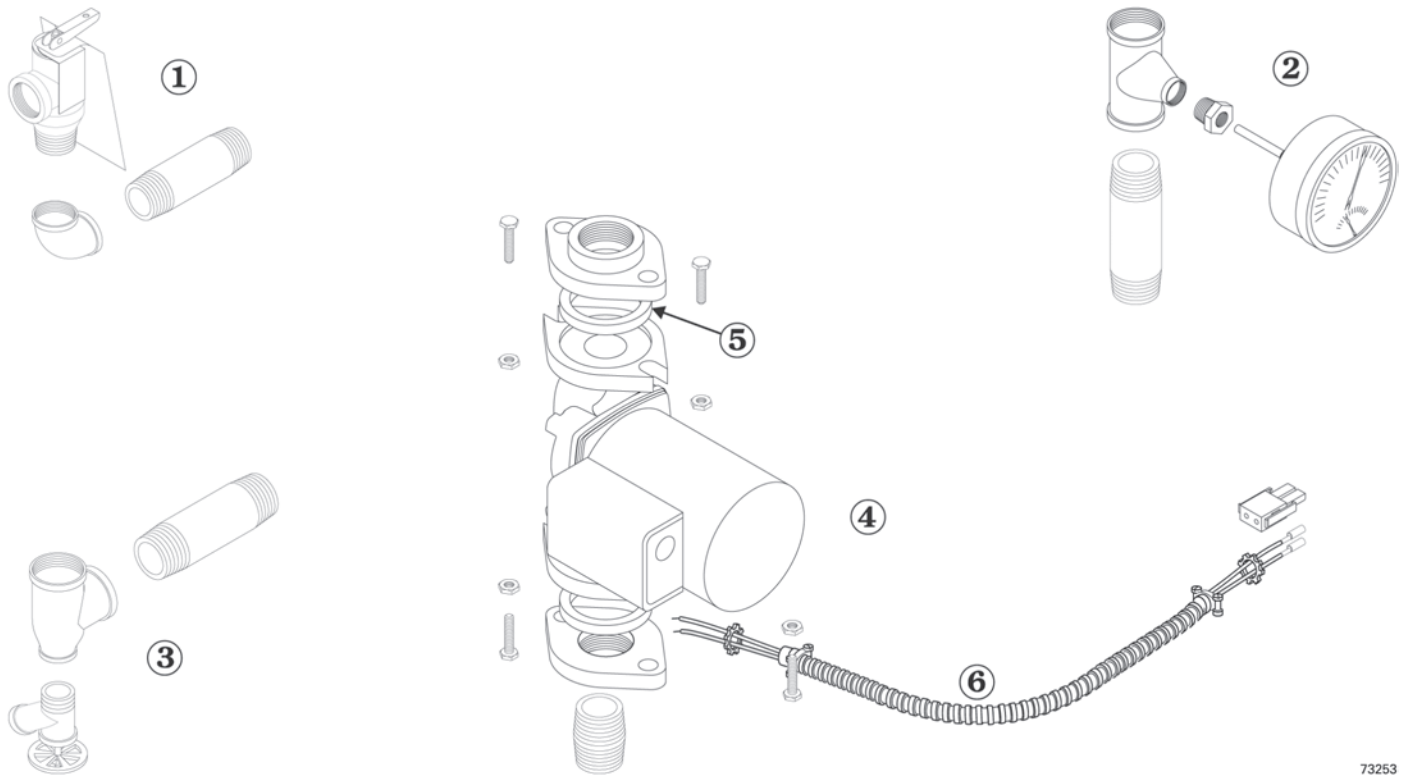

73253

Item number	Description	Manufacturer	Manufacturer's part number	Part number
1	Pressure relief valve, ASME, 30 PSIG, ¼" male inlet	Conbraco Watts	10-407-10 M330	511-546-920WT
	Pressure relief valve, ASME, 30 PSIG, ¼" female inlet (Fittings shown are factory-installed on boiler.)	Conbraco Watts	10-408-05 335	511-546-924WT
2	Combination pressure-temperature gauge, with 2½" short shank	Ametek ENFM	PTA-1088 4104	510-218-099WT
3	Drain valve, ¼" (Fittings shown are included with boiler.)	Conbraco Hammond Valve Matco-Norca Watts	31-606-01 710 205F04 BD-2C	511-210-423WT
4	Circulator (Fittings shown are shipped loose with boiler.)	Taco	007	511-405-113WT
5	Circulator gasket, universal (2 per boiler)			590-317-535WT
not shown	Circulator hardware kit, includes: 2 flanges, 4 nuts, 4 screws, 2 pipe nipples — 1" NPT			381-354-525WT
6	Circulator wiring harness kit, with Molex (loose)			381-354-528WT

# 13 Replacement parts *continued*

**Figure 19** Gas control assembly

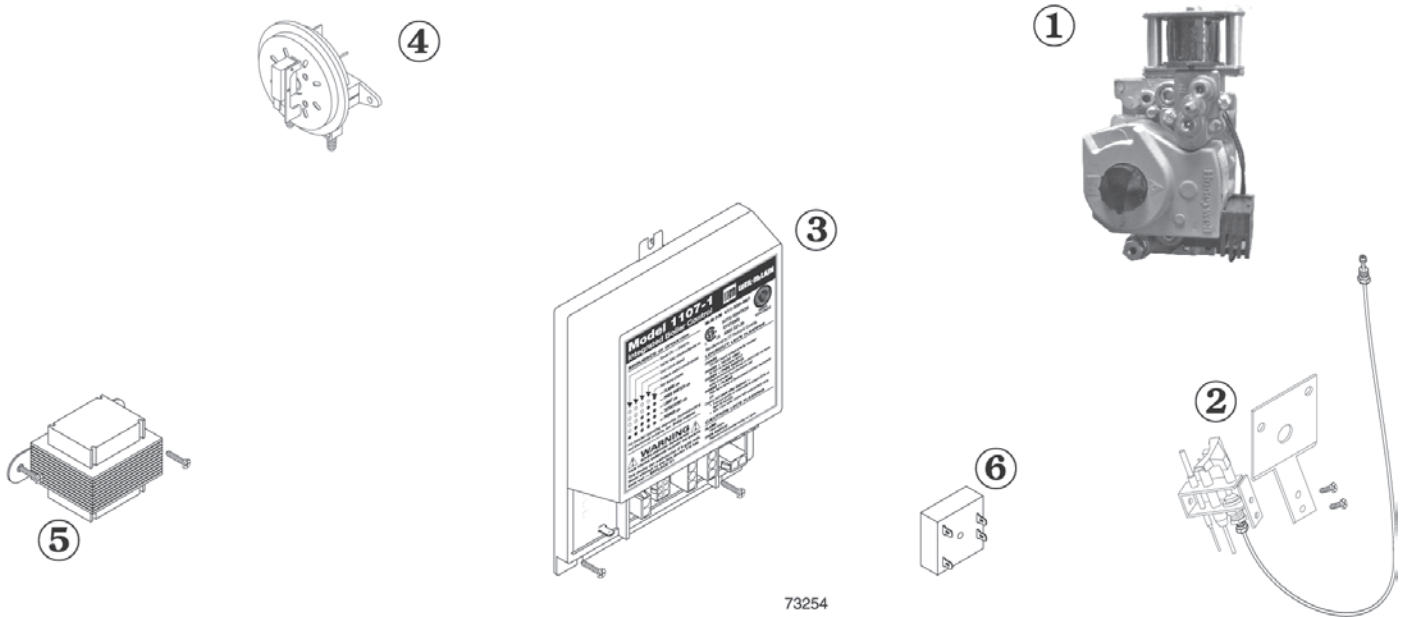

Item number	Description	Manufacturer	Manufacturer's part number	Part number
<b>Natural gas components</b>				
1	Gas valve, 1/2" x 1/2", two-stage Natural gas	Honeywell	VR8204Q2426	511-044-507WT
2	Pilot assembly kit with orifice and aluminum pilot gas tubing	Weil-McLain		511-330-080WT
<b>Propane gas components</b>				
1	Gas valve, 1/2" x 1/2", two-stage Propane	Honeywell	VR8204Q2442	511-044-509WT
2	Pilot assembly kit with orifice and aluminum pilot gas tubing	Weil-McLain		511-330-081WT
<b>Natural gas and propane gas components</b>				
3	Control module	United Technologies	1107-1	511-330-090WT
not shown	Wiring harness — control	Weil-McLain		591-391-952WT
not shown	Wiring harness — 120V	Weil-McLain		591-391-900WT
not shown	Timer harness #1	Weil-McLain		591-391-954WT
4	Air pressure switch 1.71 I.W.C. — GWS-090E	Cleveland	NS2-1047-08	511-624-656WT
5	Control transformer			511-842-370WT
6	Timer relay *	ABB	TS12190	510-350-468WT
not shown	Tubing, air pressure switch, 0.12 I.D. silicone red, to collector hood white, to transition	Lydall		590-317-650WT 590-317-651WT

\* The ABB timer relay TS12190 is designed for 90-second delay, but operates for 60 seconds in the GWS-090E boiler.

# 14 Dimensions

**Figure 20** Dimensional drawing — **ALL DIMENSIONS IN INCHES**

- ① Supply, 1¼" NPT (Note 1)
- ② Return, 1¼" NPT (Note 1)
- ③ Relief valve, ¾" NPT
- ④ ½" NPT to expansion tank/air vent
- ⑤ 3" Diameter vent
- ⑥ 3"¾" Diameter combustion air pipe connection
- ⑦ Gas supply piping
- ⑧ Drain valve
- ⑨ Gas supply entrance (right or left side)
- ⑩ Pressure/temperature gauge

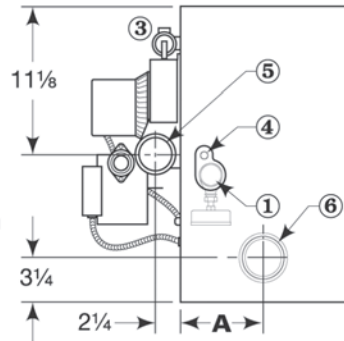

**TOP VIEW**

**Note 1:** Boiler supply and return tapings are both 1¼" NPT. See Table 5, page 9, for recommended system supply and return piping sizes.

**Note 2:** Boiler circulator is shipped loose. Circulator may be mounted on either boiler supply or return piping. Circulator flange provided with boiler is same size as recommended pipe size in Table 5, page 9.

**ALL DIMENSIONS IN INCHES**

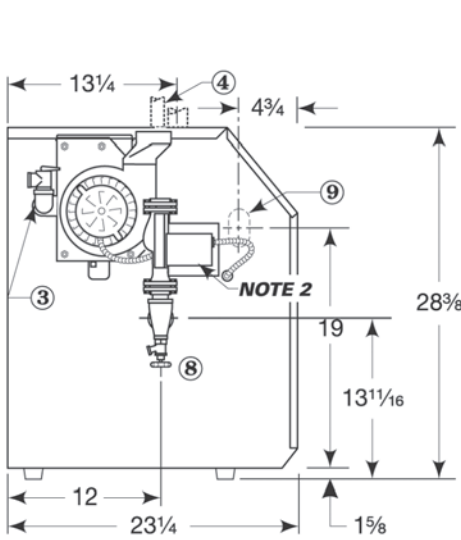

**LEFT SIDE**

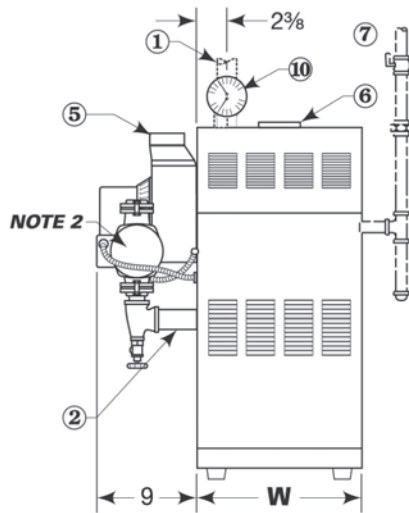

**FRONT**

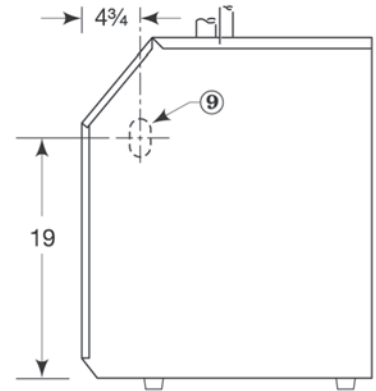

**RIGHT SIDE**

73260

Boiler model number	Supply tapping (inches NPT)	Return tapping (inches NPT)	Gas connection size Note 3 (inches NPT)	Gas manifold size Note 3 (inches NPT)	"A" Air inlet pipe center (inches)	"W" Jacket width (inches)
GWS-090E	1 ¼	1 ¼	½	½	8	16

Note 3: Gas piping from meter to boiler to be sized per local utility requirements.

# 15 Ratings



**DOE**



Boiler model number	0–2,000 feet altitude		2,000–4,500 feet altitude (Canada)		Net I=B=R ratings (Btuh)	Boiler water content (gallons)	DOE seasonal efficiency (% A.F.U.E)	Vent size
	Input (Btuh)	DOE Heating Capacity (Output) (Btuh)	Input (Btuh)	Output (Btuh)				
(Note 1)		(Note 2)	(Note 6)		(Note 3)		(Note 5)	(Note 4)
<b>GWS-090E</b> (Note 5)	90,000	77,000	81,000	69,300	67,000	2.1	85.0	3"

1. Add “N-I” for natural gas boiler — “P-I” for propane gas boiler.
2. Based on standard test procedures prescribed by the United States Department of Energy.
3. Net I=B=R ratings are based on net installed radiation of sufficient quantity for the requirements of the building and nothing need be added for normal piping and pickup. Ratings are based on a piping and pickup allowance of 1.15. An additional allowance should be made for unusual piping and pickup loads.
4. The GWS-090E boiler requires special venting, consistent with Category III or IV boiler. Use only the vent materials and methods specified in GWS Vent Manual. The GWS-090E boiler may be direct-vented (using 3” diameter air piping) as specified in the GWS Vent Manual.
5. As an Energy Star Partner, W-T has determined that the GWS-090E meets the Energy Star guidelines for energy efficiency.
6. The boiler must be equipped with specially-sized orifices for high altitude applications. See page 8 for details.

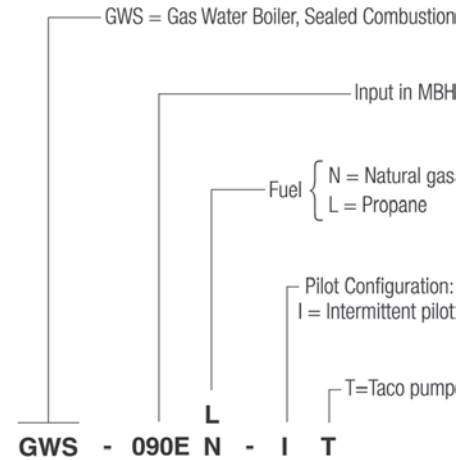

**NOTICE** Install GWS-090E boilers for residential radiant panel systems, converted gravity heating systems or other low water temperature applications per instructions in this manual to avoid damage due to condensation. GWS-090E boilers are CSA design certified for installation on combustible flooring. GWS-090E boilers are ASME rated for 50 psig working pressure.

## Addendum Instruction for the Commonwealth of Massachusetts

### **WARNING**

This addendum must only be used by a qualified heating installer/service technician. Read these instructions completely before beginning the installation. Failure to comply could result in severe personal injury, death or substantial property damage.

(a) For all side wall horizontally vented gas fueled equipment installed in every dwelling, building or structure used in whole or in part for residential purposes, including those owned or operated by the Commonwealth and where the side wall exhaust vent termination is less than seven (7) feet above finished grade in the area of the venting, including but not limited to decks and porches, the following requirements shall be satisfied:

1. **INSTALLATION OF CARBON MONOXIDE DETECTORS.** At the time of installation of the side wall horizontal vented gas fueled equipment, the installing plumber or gas fitter shall observe that a hard wired carbon monoxide detector with an alarm and battery back-up is installed on the floor level where the gas equipment is to be installed. In addition, the installing plumber or gas fitter shall observe that a battery operated or hard wired carbon monoxide detector with an alarm is installed on each additional level of the dwelling, building or structure served by the side wall horizontal vented gas fueled equipment. It shall be the responsibility of the property owner to secure the services of qualified licensed professionals for the installation of hard wired carbon monoxide detectors
  - a. In the event that the side wall horizontally vented gas fueled equipment is installed in a crawl space or an attic, the hard wired carbon monoxide detector with alarm and battery back-up may be installed on the next adjacent floor level.
  - b. In the event that the requirements of this subdivision can not be met at the time of completion of installation, the owner shall have a period of thirty (30) days to comply with the above requirements; provided, however, that during said thirty (30) day period, a battery operated carbon monoxide detector with an alarm shall be installed.
2. **APPROVED CARBON MONOXIDE DETECTORS.** Each carbon monoxide detector as required in accordance with the above provisions shall comply with NFPA 720 and be ANSI/UL 2034 listed and IAS certified.
3. **SIGNAGE.** A metal or plastic identification plate shall be permanently mounted to the exterior of the building at a minimum height of eight (8) feet above grade directly in line with the exhaust vent terminal for the horizontally vented gas fueled heating appliance or equipment. The sign shall read, in print size no less than

one-half (1/2) inch in size, “GAS VENT DIRECTLY BELOW. KEEP CLEAR OF ALL OBSTRUCTIONS.”

4. **INSPECTION.** The state or local gas inspector of the side wall horizontally vented gas fueled equipment shall not approve the installation unless, upon inspection, the inspector observes carbon monoxide detectors and signage installed in accordance with the provisions of 248 CMR 5.08(2)(a) 1 through 4.
- (b) **EXEMPTIONS:** The following equipment is exempt from 248 CMR 5.08(2)(a)1 through 4:
  1. The equipment listed in Chapter 10 entitled “Equipment Not Required To Be Vented” in the most current edition of NFPA 54 as adopted by the Board; and
  2. Product Approved side wall horizontally vented gas fueled equipment installed in a room or structure separate from the dwelling, building or structure used in whole or in part for residential purposes.
- (c) **MANUFACTURER REQUIREMENTS — GAS EQUIPMENT VENTING SYSTEM PROVIDED.** When the manufacturer of Product Approved side wall horizontally vented gas equipment provides a venting system design or venting system components with the equipment, the instructions provided by the manufacturer for installation of the equipment and the venting system shall include:
  1. Detailed instructions for the installation of the venting system design or the venting system components; and
  2. A complete parts list for the venting system design or venting system.
- (d) **MANUFACTURER REQUIREMENTS — GAS EQUIPMENT VENTING SYSTEM NOT PROVIDED.** When the manufacturer of a Product Approved side wall horizontally vented gas fueled equipment does not provide the parts for venting the flue gases, but identifies “special venting systems”, the following requirements shall be satisfied by the manufacturer:
  1. The referenced “special venting system” instructions shall be included with the appliance or equipment installation instructions; and
  2. The “special venting systems” shall be Product Approved by the Board, and the instructions for that system shall include a parts list and detailed installation instructions.
- (e) A copy of all installation instructions for all Product Approved side wall horizontally vented gas fueled equipment, all venting instructions, all parts lists for venting instructions, and/or all venting design instructions shall remain with the appliance or equipment at the completion of the installation.

W-T  
8201 W. Calumet Rd.  
Milwaukee, WI 53223