

GWC

Series 2

Gas-Fired Water Boilers

User's Information Manual



▲ WARNING

If the information in this manual is not followed exactly, a fire or explosion may result, causing property damage, personal injury or loss of life.

Do not store or use gasoline or other flammable vapors and liquids in the vicinity of this or any other appliance.

— WHAT TO DO IF YOU SMELL GAS —

- Do not try to light any appliance.
- Do not touch any electrical switch; do not use any telephone in your building.
- Immediately call your gas supplier from a neighbor's telephone. Follow the gas supplier's instructions.
- If you cannot reach your gas supplier, call the fire department.

Installation & service must be performed by a qualified installer, service technician or the gas supplier.

Please read this page first

How to use this manual . . .

To . . .	Read/use . . .	Page . . .
Learn precautions	Warnings and definitions	3
Prevent air contamination	Laundry room or pool — make sure boiler air is piped to boiler per manual. Read list of air contaminants you must avoid. Have boiler air piped in if you can't avoid.	4
Maintain boiler	Set up a plan for maintaining the boiler using the schedule included in this manual. Schedule an annual start-up by a qualified service technician before every heating season.	5
Locate boiler components	<i>How the boiler works</i> and illustration.	10
Start — or — Shutdown boiler	Follow the Operating instruction sheet details to start or shutdown your boiler.	12
Troubleshoot common problems	Use the common problems/solutions table to resolve typical heating system/boiler problems.	13

Hazard definitions

The following defined terms are used throughout this manual to bring attention to the presence of hazards of various risk levels or to important information concerning the life of the product.

⚠ DANGER Indicates presence of hazards that will cause severe personal injury, death or substantial property damage.

⚠ WARNING Indicates presence of hazards that can cause severe personal injury, death or substantial property damage.

⚠ CAUTION Indicates presence of hazards that will or can cause minor personal injury or property damage.

NOTICE Indicates special instructions on installation, operation or maintenance that are important but not related to personal injury or property damage.

Boiler service and maintenance

⚠ WARNING The Boiler manual is for use only by a qualified heating installer/service technician. Refer only to this User's Information Manual for your reference. Improper installation, adjustment, alteration, service or maintenance can cause property damage, personal injury (exposure to hazardous materials) or loss of life. Installation and service must be performed by a qualified installer, service agency or the gas supplier (who must read and follow the supplied instructions before installing, servicing, or removing this boiler. This boiler contains materials that have been identified as carcinogenic, or possibly carcinogenic, to humans).

NOTICE When calling or writing about the boiler— Please have the boiler model number from the boiler rating label and the CP number from the label located on the top of the boiler next to the air inlet connection.

STOP!! — Read before proceeding

⚠ WARNING **User** — Have this boiler serviced/inspected by a qualified service technician, at least annually.

⚠ WARNING Failure to adhere to the guidelines on this page can result in severe personal injury, death or substantial property damage.

Boiler service and maintenance —

- To avoid electric shock, **disconnect all electrical supplies** to the boiler before performing maintenance if wiring will be exposed.
- To avoid severe burns, **allow boiler to cool** before performing maintenance.
- You must **maintain** the boiler as outlined in this manual and have the boiler **started up and serviced at least annually by a qualified service technician** to ensure boiler/system reliability.

Boiler operation —

- Do not block flow of combustion or ventilation air to boiler. This boiler is equipped with a control which will automatically shut down the boiler should air or vent be blocked. If vent or air blockage is easily accessible and removable, remove it. The boiler should attempt to restart within an hour. (If blockage is not obvious or cannot be removed, have the boiler and system checked by a qualified service technician.)
- Do not allow contaminated air to enter the boiler room (or air inlet pipe if direct vented). See page 4 for details.
- Should overheating occur or gas supply fail to shut off**, do not turn off or disconnect electrical supply to boiler. Instead, shut off the gas supply at a location external to the appliance.
- Do not use this boiler if any part has been under water.** Immediately call a qualified service technician to inspect the boiler and to replace any part of the control system and any gas control that has been under water.
- Should overheating occur or gas supply fail to shut off**, DO NOT turn off or disconnect electrical supply to circulator. Instead, shut off the gas supply at a location external to the appliance.

Combustion air —

- DO NOT install combustion air intake where there is a risk of combustion air contamination.**

Carbon monoxide detector —

- For **Direct Exhaust** units, a carbon monoxide detector is required in the boiler room. The carbon monoxide detector must be wired on the same electrical circuit as the boiler.
- For **Direct Vent** units, a carbon monoxide detector that is wired on the same electrical circuit as the boiler is strongly recommended.

Boiler water —

- Have boiler water chemistry checked at least annually by a qualified service technician.
- DO NOT use petroleum-based cleaning or sealing compounds in boiler system. Gaskets and seals in the system may be damaged. This can result in substantial property damage.
- DO NOT use “homemade cures” or “boiler patent medicines”. Serious damage to boiler, personnel and/or property may result.
- Leaks in boiler or piping must be repaired at once to prevent make-up water. Use this boiler ONLY in a closed-loop system.** Continual fresh make-up water will reduce boiler life. Mineral buildup in heat exchangers reduces heat transfer, overheats the materials, and causes failure. Addition of oxygen carried in by make-up water can cause internal corrosion.
- Do not add cold water to hot boiler.** Thermal shock can cause boiler heat exchanger to crack.

Freeze protection fluids —

- NEVER use automotive or standard glycol antifreeze. Use only freeze-protection fluids made for hydronic systems. Follow all guidelines given by the antifreeze manufacturer. Thoroughly clean and flush any replacement boiler system that has used glycol before installing the new boiler.

⚠ CAUTION Frozen Water Damage Hazard

Residences or buildings that are unattended in severely cold weather, boiler system components failures, power outages, or other electrical system failures could result in frozen plumbing and water damage in a matter of hours. For your protection, take preventative actions such as having a security system installed that operates during power outages, senses low temperature, and initiates an effective action. Consult with your boiler contractor or a home security agency.

⚠ DANGER **If any part of a boiler, burner or its controls has been sprayed with or submerged under water, either partially or fully, DO NOT attempt to operate the boiler until the boiler has been either replaced or completely repaired, inspected, and you are sure that the boiler and all components are in good condition and fully reliable.** Otherwise, by operating this boiler, you will cause a fire or explosion hazard, and an electrical shock hazard, leading to serious injury, death, or substantial property damage. See the instructions at right.

Saltwater Damage — The exposure of boiler components to saltwater can have both immediate and long-term effects. While the immediate effects of saltwater damage are similar to those of freshwater (shorting out of electrical components, washing out of critical lubricants, etc.), the salt and other contaminants left behind can lead to longer term issues after the water is gone due to the conductive and corrosive nature of the salt residue. Therefore, Weil-McLain equipment contaminated with saltwater or polluted water will no longer be covered under warranty and should be replaced.

Electrical Damage — If any **electrical component or wiring** came into contact with water, or was suspected to have come into contact with water, replace the boiler with a new Weil-McLain boiler.

Prevent combustion air contamination —

Air contamination

Common household and hobby products often contain fluorine or chlorine compounds. When these chemicals pass through the boiler, they can form strong acids in the vent system or boiler. The acid can eat through the vent or boiler wall, causing serious damage and presenting a possible threat of flue gas spillage into the building.

Please read the information below. If the contaminating chemicals will be present, have your installer pipe the boiler air from outside per the Boiler manual.

WARNING If the boiler is installed in **any area likely to cause contamination**, or if products which would contaminate the air cannot be removed, you must **pipe combustion air to the boiler** air intake. Contaminated combustion air will damage the boiler and vent system, resulting in possible severe personal injury, death or substantial property damage.

Do not operate a GWC boiler in a laundry room or pool facility, for example, without using ducted outside air. These areas will always contain contaminants.

Combustion air contamination:

WARNING Ensure that the combustion air will not contain any of the contaminants in Figure 1.

Combustion air supply openings or intake terminations must NOT be near a swimming pool, for example.

Avoid areas subject to exhaust fumes from laundry facilities. These areas will always contain contaminants.

Figure 1 Corrosive contaminants and sources

Products to avoid
Spray cans containing chloro/fluorocarbons
Permanent wave solutions
Chlorinated waxes/cleaners
Chlorine-based swimming pool chemicals
Calcium chloride used for thawing
Sodium chloride used for water softening
Refrigerant leaks
Paint or varnish removers
Hydrochloric acid/muriatic acid
Cements and glues
Antistatic fabric softeners used in clothes dryers
Chlorine-type bleaches, detergents, and cleaning solvents found in household laundry rooms
Adhesives used to fasten building products and other similar products
Excessive dust and dirt
Areas likely to have contaminants
Dry cleaning/laundry areas and establishments
Swimming pools
Metal fabrication plants
Beauty shops
Refrigeration repair shops
Photo processing plants
Auto body shops
Plastic manufacturing plants
Furniture refinishing areas and establishments
New building construction

Perform maintenance per schedule below

Figure 2 Service and maintenance schedules

Service technician (see Boiler Manual for instructions)		Owner maintenance (see following pages for instructions)		
Annual start-up	Follow the procedures listed in the Boiler Manual.			
	Daily	<ul style="list-style-type: none"> • Check boiler area • Check air openings • Check pressure gauge 		
	Monthly	<ul style="list-style-type: none"> • Check boiler interior piping • Check venting system • Check air vents • Check condensate drain system • Check relief valve 		
	Periodically	<ul style="list-style-type: none"> • Test low water cutoff (if used) • Clean vent termination/air intake screens 		
	Every 6 months	<ul style="list-style-type: none"> • Oil blower motor • Operate relief valve 		
	End of season	<ul style="list-style-type: none"> • Shut down procedure 		

User maintenance procedures

**Boiler must
be serviced and
maintained**

⚠ WARNING The boiler should be inspected and started annually, at the beginning of the heating season, only by a qualified service technician. In addition, the maintenance and care of the boiler designated on page 5 and explained on the following pages must be performed to assure maximum boiler efficiency and reliability. Failure to service and maintain the boiler and system could result in equipment failure, causing possible severe personal injury, death or substantial property damage.

⚠ CAUTION The following information provides detailed instructions for completing the maintenance items listed in the maintenance schedule, page 5. In addition to this maintenance, the boiler must be serviced and started up at the beginning of each heating season by a qualified service technician.

DAILY Maintenance

Check boiler area

⚠ WARNING To prevent potential of severe personal injury, death or substantial property damage, eliminate all materials discussed below from the boiler vicinity. If contaminants are found:

Remove products immediately from the area. If they have been there for an extended period, call a qualified service technician to inspect the boiler and vent system for possible damage from acid corrosion.

If products cannot be removed, immediately call a qualified service technician to install an outside combustion air source for the boiler (if not already installed).

1. Combustible/flammable materials — Do not store combustible materials, gasoline or any other flammable vapors or liquids near the boiler. Remove immediately if found.
2. Air contaminants — Products containing chlorine or fluorine, if allowed to contaminate the boiler intake air, will cause acidic condensate in the vent and boiler. This will cause significant damage to the vent and/or boiler if allowed to continue. Read the list of potential materials listed on page 4 of this manual. If any of these products are in the room from which the boiler takes its combustion air, they must be removed immediately or the boiler combustion air must be supplied from outside. See WARNING above.

Check air openings

1. Verify that combustion and ventilation air openings to the boiler room and/or building are open and unobstructed.
2. Verify that boiler vent discharge and air intake are clean and free of obstructions. Remove any debris on the air intake or flue exhaust openings.

Check boiler pressure/temperature gauge

1. Make sure the pressure reading on the boiler pressure/temperature gauge does not exceed 24 psig. Higher pressure may indicate a problem with the expansion tank.
2. Contact a qualified service technician if problem persists.

User maintenance procedures *(continued)*

MONTHLY Maintenance

Check boiler interior piping

1. Remove boiler jacket top.
2. Visually inspect for leaks around internal piping, circulators, relief valve and other fittings. Immediately call a qualified service technician to repair any leaks.

▲WARNING Have leaks fixed at once by a qualified service technician. Continual fresh makeup water will reduce boiler life. Minerals can build up in sections, reducing heat transfer, overheating cast iron, and causing section failure.

▲WARNING Do not use **petroleum-based cleaning or sealing compounds** in boiler system. Severe damage to boiler and system components can occur, resulting in possible severe personal injury, death or substantial property damage.

Check venting system

1. Visually inspect the flue gas vent piping for any signs of blockage, leakage or deterioration of the piping. Notify your qualified service technician at once if you find any problem.

▲WARNING Failure to inspect the vent system as noted above and have them repaired by a qualified service technician can result in vent system failure, causing severe personal injury or death.

Check automatic air vents (if used — use automatic air vents with diaphragm-type expansion tanks only)

1. See Figure 3.
2. Remove the cap from any automatic air vent in the system and check operation by depressing valve "B" slightly with the tip of a screwdriver.
3. If the air vent valve appears to be working freely and not leaking, replace cap "A", twisting all the way on.
4. Loosen cap "A" one turn to allow vent to operate.
5. Have vent replaced if it does not operate correctly.

Figure 3 Automatic air vent

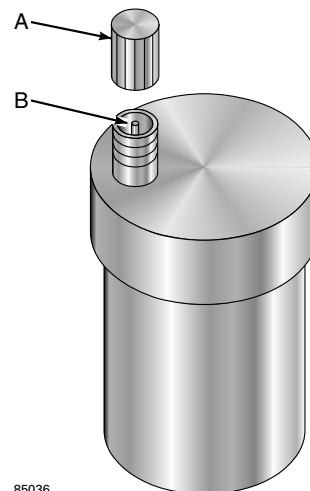

85036

User maintenance procedures *(continued)*

MONTHLY Maintenance

Check condensate system

1. NOTICE — To improve clarity, this illustration of the condensate trap is shown with no air inlet pipe attached. If your boiler has an air pipe connected here, DO NOT tamper with it. The trap is also shown as item **L** on page 11.
2. Inspect the condensate P-trap (item 1 in the illustration at right). If the trap does not contain water, turn off the boiler ON/OFF switch and call your boiler service technician immediately.
3. Item 2 in the illustration is the drain tubing to the condensate pump. Inspect this tubing or piping, making sure it is in good condition and not obstructed.

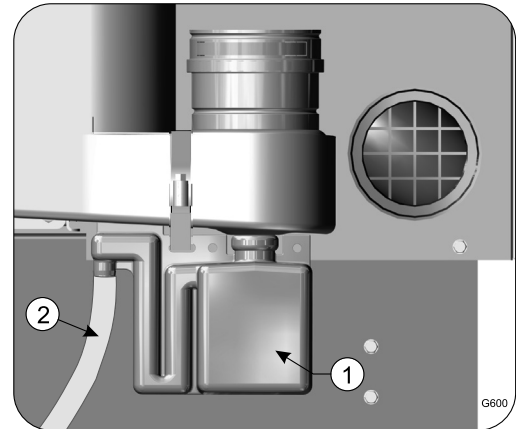

⚠ WARNING If the condensate trap is dry or the condensate line is damaged or obstructed, there is a risk of flue gas flow into the building. The boiler must not be operated and must be inspected and serviced only by a qualified service technician. Failure to comply with this directive could result in the possibility of severe personal injury, death or substantial property damage.

Check boiler relief valve

1. Inspect the boiler relief valve and the relief valve discharge pipe for signs of weeping or leakage.
2. If the relief valve often weeps, the expansion tank may not be working properly. Immediately contact your qualified service technician to inspect the boiler and system.

PERIODIC Maintenance

Test low water cutoff (if installed)

1. If the system is equipped with a low water cutoff, test the low water cutoff periodically during the heating season, following the low water cutoff manufacturer's instructions.

Clean vent termination & air intake screens

1. Remove all lint and debris from both the boiler air intake screen and the flue discharge screen.
2. The boiler control module will sense blockage of the air intake or flue and lockout if the blockage is excessive. It will signal the failure by flashing the appropriate indicator lights on the control board.
3. If removing the debris does not allow the boiler to operate correctly afterwards, contact your qualified service technician to inspect the boiler and vent/air systems.

User maintenance procedures *(continued)*

**EVERY
6 MONTHS
Maintenance**

Oil blower motor

1. Remove the jacket top panel to access the blower motor.
2. Use only Anderol 465. DO NOT use household universal oils.

⚠ WARNING Use only Anderol 465 to lubricate the blower motor. Do not use common universal household oils.

3. See Figure 4
4. Place a few drops of oil in each of the two oiler cups on the side of the blower motor.

Figure 4 Blower motor

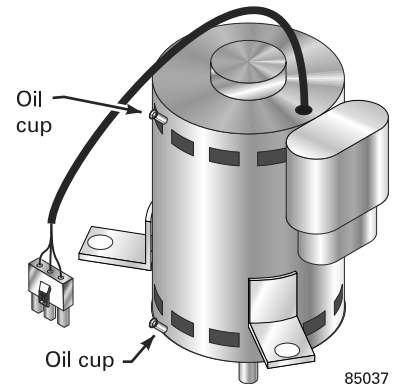

Operate boiler relief valve

1. Before proceeding, verify that the relief valve outlet has been piped to a safe place of discharge, avoiding any possibility of scalding from hot water.

⚠ WARNING To avoid water damage or scalding due to valve operation, a metal discharge line must be connected to relief valve outlet and run to a safe place of disposal. This discharge line must be installed by a qualified heating installer or service technician in accordance with the instructions in the **GWC Boiler Manual**. The discharge line must be terminated so as to eliminate possibility of severe burns should the valve discharge.

2. Read the boiler pressure/temperature gauge to make sure the system is pressurized.
3. Lift the relief valve top lever slightly, allowing water to relieve through the valve and discharge piping.
4. If water flows freely, release the lever and allow the valve to seat. Watch the end of the relief valve discharge pipe to ensure that the valve does not weep after the line has had time to drain. If the valve weeps, lift the seat again to attempt to clean the valve seat. If the valve continues to weep afterwards, contact your qualified service technician to inspect the valve and system.
5. If water does not flow from the valve when you lift the lever completely, the valve or discharge line may be blocked. Immediately shutdown the boiler, following the lighting instructions on the inside jacket top. Call your qualified service technician to inspect the boiler and system.

**END OF
SEASON
Maintenance**

Follow boiler shutdown procedure

1. Follow “**TO TURN OFF GAS TO APPLIANCE**” on the **Operating instruction** on the inside of the jacket top panel. You will also find these instructions on page 12 of this manual.
2. Do not drain system unless exposure to freezing temperatures will occur.
3. Do not drain the system if it is filled with an antifreeze solution.
4. Do not shut down boilers used for domestic water heating. They must operate year-round.

How it works . . .

1 Integrated boiler control

The integrated boiler control (IBC) responds to signals from the room thermostat, air pressure switch, inlet water sensor, boiler water temperature sensor and boiler limit circuit to operate the circulators, gas valve, igniter and blower. When a room thermostat calls for heat, the IBC starts the system circulator and blower.

The IBC runs the blower to purge the boiler flue passages, then turns on the igniter and lets it warm up.

After igniter warm-up, the IBC opens the gas valve, turns the igniter off, and checks for flame. The flame must come on within 4 seconds or the IBC will shut down and try the full cycle again.

When the room thermostat is satisfied, the IBC turns off the boiler components and waits for the next heat call.

The IBC indicator lights show normal sequence when the lights are on steady. When a problem occurs, the IBC flashes combinations of lights which indicate the most likely reason for the problem.

While attempting to satisfy the heat demand, the control module monitors the boiler temperature changes via the temperature sensors and determines whether or not the available hot water will satisfy the demand, only running the circulator. If additional heat is needed, the sequence continues. When DHW (if used) calls for heat, sequence above is bypassed.

2 Transformer

The control transformer reduces line voltage to 24 volts for the gas valve and limit circuit.

3 Blower

The blower pulls in air and mixes it with gas from the gas valve. The blower forces this mixture into the burner for combustion inside the boiler chamber.

4 Recuperator

The recuperator is a stainless steel heat exchanger that increases boiler efficiency by extracting additional heat from the flue gases. Return water passes through the recuperator before entering the boiler.

5 Water temperature sensor

The water temperature sensor provides a signal to the control module to turn off the gas valve if the temperature in the boiler goes above its setting. (The circulator will continue to run as long as there is a call for heat.)

6 System circulator

The system circulator circulates water through the external (system) piping. The flow rate of the circulator is controlled by the IBC, depending on the temperature of the water entering the boiler sections. Pump must remain on boiler — do not remove.

7 Bypass circulator

The IBC operates the bypass circulator to mix hot water from the boiler outlet with colder return water from the system as needed to prevent condensation of flue gases in the cast iron heat exchanger.

When the water returning to the boiler is below 140°F, the IBC regulates the bypass circulator and system circulator flow rates to raise the return water temperature up to 140°F before it enters the cast iron sections. By balancing these flow rates, the IBC can protect against condensation even if return water is as low as 60°F.

Pump must remain on boiler — do not remove.

8 Air pressure switch

The air pressure switch signals the IBC, telling the control whether air is moving through the blower.

9 Return water temperature sensor

The water temperature sensor monitors the temperature of the water entering the boiler sections. The sensor sends this information to the IBC. The IBC determines how much to adjust the circulator flow rates to provide at least 140°F water to the cast iron heat exchanger.

LEGEND

- a Supply to system, 1" NPT
- b Return from system, 1" NPT
- c Combustion air inlet fitting — 3" PVC connection
- d Flue outlet — 3" PVC connection
- e Gas valve — negative pressure regulated gas control
- f Pressure/temperature gauge
- g Flueway inspection port cover
- h Sensor hose trap
- i Manual air vent
- j Relief valve
- k Thermal switch — a device that shuts boiler off if flue temperature exceeds its setpoint
- l Condensate trap line — shipped loose with boiler, field installed

WARNING

This boiler uses a negative-pressure-regulated gas valve, set for an outlet pressure approximately -0.20" water column.

DO NOT set the outlet pressure higher than factory setting.

GWC Series 2 Water Boiler

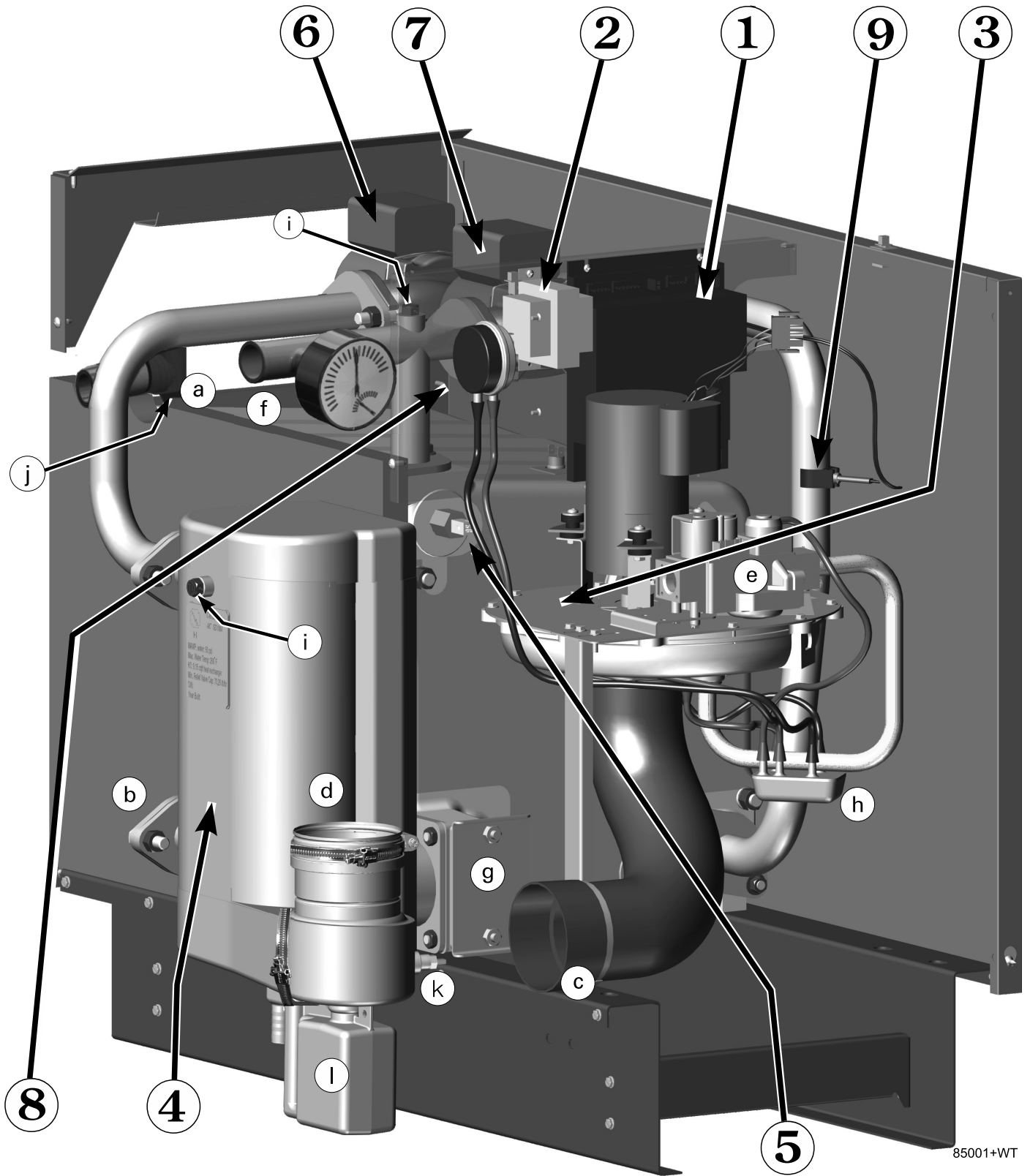

85001+WT

Operating instructions

⚠ WARNING Before attempting to start the boiler, **check the boiler pressure temperature gauge**. If boiler and system are full of water and properly pressurized, the gauge should read at least 12 psig on most systems. Operating the boiler without proper water content will damage boiler and controls and could result in severe personal injury, death or substantial property damage.

Figure 5 Operating instructions

FOR YOUR SAFETY — READ BEFORE OPERATING

⚠ WARNING If you do not follow these instructions exactly, a fire or explosion may result causing property damage, personal injury or loss of life.

- A. This appliance does not have a pilot. It is equipped with an ignition device which automatically lights the burner. Do not try to light the burner by hand.
- B. Before OPERATING, smell all around the appliance area for gas. Be sure to smell next to the floor because some gas is heavier than air and will settle on the floor. See below.
- C. Use only your hand to turn the gas control knob. Never use tools. If the knob will not turn by hand, don't try to repair it, call a qualified service technician. Force or attempted repair may result in a fire or explosion.
- D. Do not use this appliance if any part has been under water. Immediately call a qualified service technician to inspect the appliance and to replace any part of the control system and any gas control, which has been under water.

WHAT TO DO IF YOU SMELL GAS

- Do not try to light any appliance.
- Do not touch any electric switch; do not use any phone in your building.
- Immediately call your gas supplier from a neighbor's phone. Follow the gas supplier's instructions.
- If you cannot reach your gas supplier, call the fire department.

OPERATING INSTRUCTIONS

1. **STOP!** Read the safety information above on this label. This appliance is equipped with an ignition device which automatically lights the burner. Do not try to light the burner by hand.
2. Set room thermostat(s) to lowest setting.
3. Turn OFF all electrical power to the appliance.
4. Locate boiler manual gas valve (in the gas piping connected to the boiler).
5. Turn boiler manual gas valve knob counterclockwise ↺ to OPEN gas supply.
6. Wait five (5) minutes to clear out any gas. Then smell for gas, including near the floor.
7. If you smell gas, **STOP!** Turn the boiler manual gas valve to OFF. Then follow WHAT TO DO IF YOU SMELL GAS, above. If you don't smell gas, go to step 8, below.
8. Turn ON all electrical power to the appliance.
9. Set thermostat(s) to desired setting.
10. The boiler display will show symbols and/or text describing the status of the boiler as it proceeds through its operating sequence. "Standby" status means the burner is off.
11. If the appliance will not operate when there is a call for heat and piping is not hot, follow the instructions "To Turn Off Gas To Appliance" below and call your service technician or gas supplier.

Gas valve CLOSED

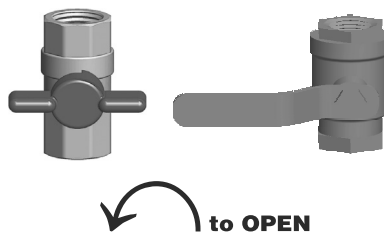

Gas valve OPEN

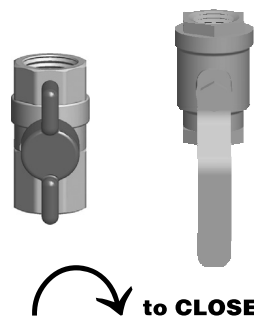

TO TURN OFF GAS TO THE APPLIANCE

1. Set room thermostats to lowest setting.
2. Turn OFF all electrical power to the appliance.
3. Turn boiler manual gas valve knob clockwise ↻ to close gas supply.

Common problems and solutions

Symptom	Common Causes	Possible Corrections
Rapid cycling — boiler turns on and off frequently	Thermostat installed where drafts or heat affect reading	Locate thermostat on inner wall away from heat sources or cool drafts.
	Heat anticipator in thermostat adjusted incorrectly	Adjust thermostat per manufacturer's instructions.
	Incorrect boiler temperature setting	Set boiler temperature according to system needs. Maximum setting is 200°F. Increase boiler temperature setting to decrease cycling.
	Insufficient water flow through boiler	Check all valves to and from boiler. Return to proper setting.
Confirm circulator size.		
Frequent release of water through relief valve	Expansion tank sized too small	Call qualified service technician to check expansion tank operation and size.
	Flooded expansion tank	Call qualified service technician to check expansion tank operation.
	Inoperative limit control	Call qualified service technician to replace limit control.
Need to frequently add makeup water	Leaks in boiler or piping	Have qualified service technician repair leaks at once to avoid constant use of makeup water. Makeup water can cause mineral deposits which, in turn, can cause boiler section failure. Do not use petroleum-base stop-leak compounds.
Black water condition	Oxygen corrosion due to leaks in boiler and piping	Have qualified service technician repair at once. Keep pH of water between 7.0 to 8.5.
Large temperature swings in living space	Incorrect Economy setting	Adjust Economy setting on boiler control.

Common problems and solutions *(continued)*

Symptom	Common Causes	Possible Corrections
Popping or percolating noise heard in boiler	Mineral deposits in sections due to constant use of makeup water	Call qualified service technician to de-lime boiler, if necessary. In some cases, deposits will be too heavy to remove with de-liming procedures.
		Have qualified service technician repair leaks to eliminate need for constant makeup water.
	Incorrect pH of boiler water	Call qualified service technician to check pH level and correct. pH should be maintained between 7.0 to 8.5.
	Insufficient water flow through boiler	Check all valves to and from boiler. Return to proper setting. Confirm circulator size.
Metal flakes found in vent outlet or vent starter tee — flueway corrosion	Contaminated combustion air supply — See page 4 in this manual.	Remove any contaminating products. See page 4 in this manual. Provide outside air for combustion. Have qualified service technician pipe-up kit.
	Condensation of combustion gases in boiler sections	Have qualified service technician check operation of mixing system. Repair/replace if necessary.
Some radiators or baseboard units do not heat or are noisy	Air in system	Bleed air from system through air vents in radiators or baseboard units.
	Low system pressure	Fill to correct pressure. Check for leaks in boiler or piping. Have qualified service technician repair at once.
	Boiler temperature set too low	Adjust boiler temperature to higher setting.

